

2022

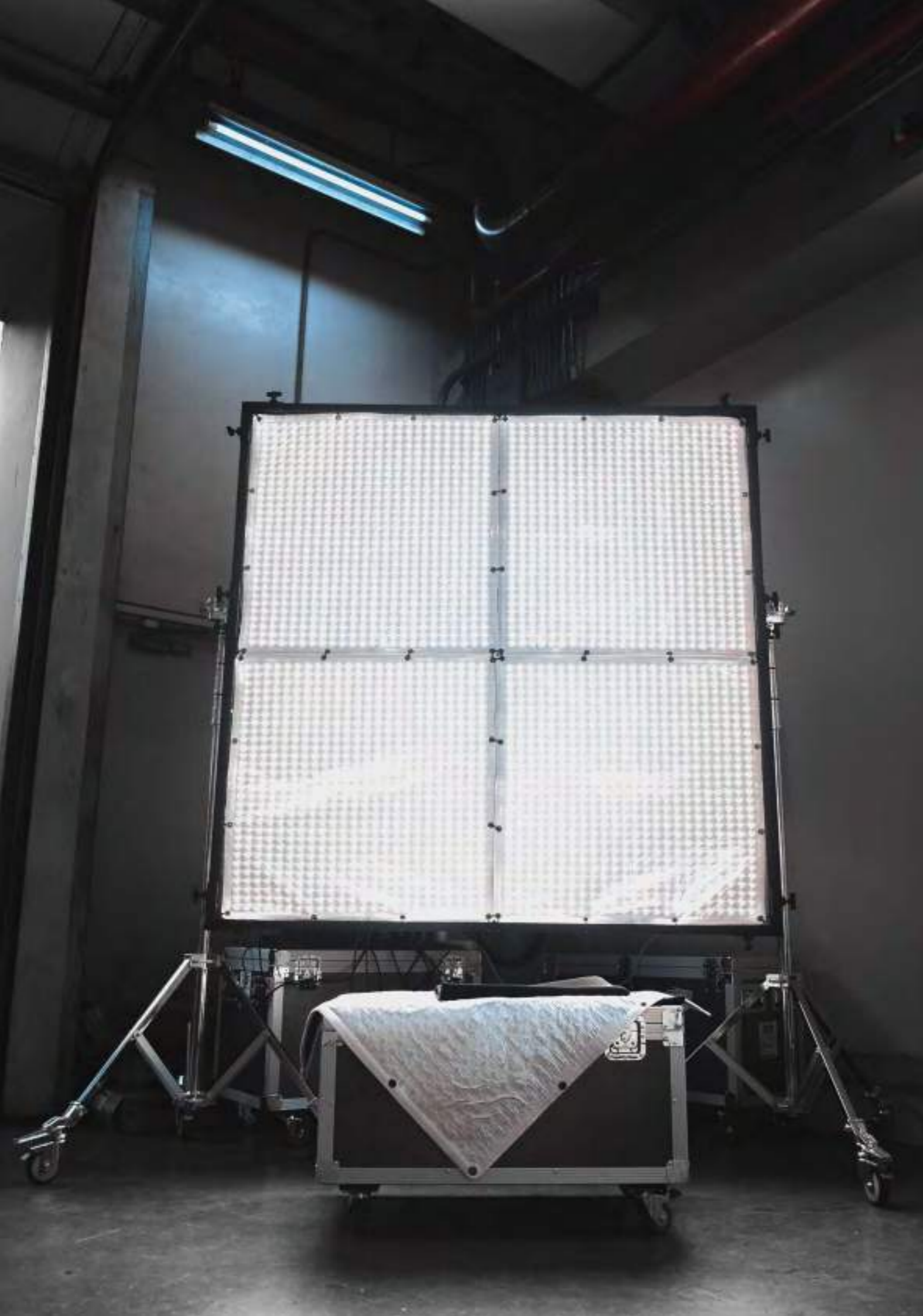

Shaddin



MOSAIC 2X4	04
MOSAIC 4X4	06
MOSAIC 3X6	08
ALL-IN LINE	10
ALL-IN 1	12
ALL-IN 2	14
WHIP-LITE	16
CAPE-LITE	18
FABRIC-LITE 200	20
FABRIC-LITE 350	22
A-LITE	24
EYE-LITE	26
BI-FLEX M3	28
BI-FLEX M7	30
BI-FABRIC 2	32
BI-FABRIC 4	34

Aladdin MOSAIC 2X4



About Mosaic 2X4

The new Aladdin MOSAIC-LITES are the result of years of customer feedback, engineering and perfecting a flexible LED panel. The results are the probably most perfect LED panels in the industry, available in three sizes. Say hello to the MOSAIC 2X4, 4X4 and 3X6 with RGB from Aladdin Lights.

The MOSAIC-LITES offer new panel sizes you have never seen before from Aladdin Lights. Finally we can happily introduce the long awaited 4X4 (600W) size to you, next to the also new 2X4 (350W) and 3x6 (600W) sizes. Those panels will give you a new advantage on set without any compromise on light quality, weight and flexibility, which you are already used to from Aladdin Lights.

These lights are made for high-end film and photography productions. All MOSAIC-LITES are RGB panels, have a CRI and TLCI over 95 and offer bluetooth connection to adjust them with the free Aladdin app right from your phone. The MOSAIC plug connection allows you to use gear like the MOSAIC Wired Dimmer (M-WDIM). The dimmer with display offers you physical dialing, a DMX port and built-in Lumenradio. For each MOSAIC size there is a fitting frame with softbox and grid, like you already know from the FABRIC-LITE. More additional accessories for the MOSAIC-LITES are expected for later this year.

For the MOSAIC-LITES we are introducing the fast changable LED compounds. They allow to replace small LED parts on your panel, without replacing the whole panel. You can either let it get fixed by one of our certified dealers or if you need a faster replacement and have the technical skill to do so, you can do it by yourself. We are providing a step by step tutorial video on how to change the LED compounds at home.

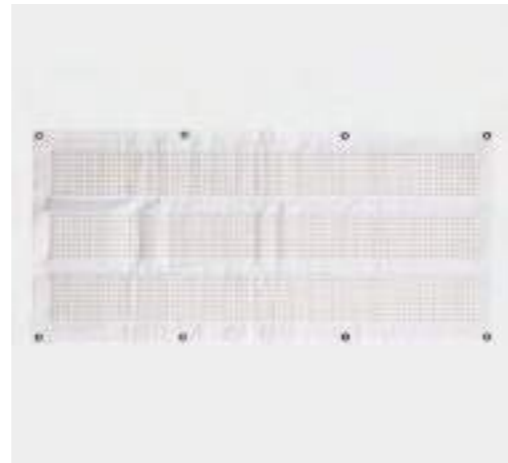

Product Catalog 2022

MOSAIC 2X4

	60cm/2ft	1m/3ft	2m/6ft	3m/9ft	CRI
Daylight 6290K	14200lux	6980lux	2240lux	1140lux	95
Tungsten 2750K	16700lux	8210lux	2640lux	1330lux	95

Specifications

Light Source	Super High CRI Power LED's 350W RGBWW
CRI	CRI 95
Beam Angle	140°
Dimmer	Dimming: 0%–100% (1% resolution)
Cooling	passive cooling
Size	55cm x 110cm
DMX	DMX / LumenRadio / Bluetooth
Input	AC/DC 100-240V / 48V



Aladdin MOSAIC 4X4



About Mosaic 4X4

The new Aladdin MOSAIC-LITES are the result of years of customer feedback, engineering and perfecting a flexible LED panel. The results are the probably most perfect LED panels in the industry, available in three sizes. Say hello to the MOSAIC 2X4, 4X4 and 3X6 with RGB from Aladdin Lights.

The MOSAIC-LITES offer new panel sizes you have never seen before from Aladdin Lights. Finally we can happily introduce the long awaited 4X4 (600W) size to you, next to the also new 2X4 (350W) and 3x6 (600W) sizes. Those panels will give you a new advantage on set without any compromise on light quality, weight and flexibility, which you are already used to from Aladdin Lights.

These lights are made for high-end film and photography productions. All MOSAIC-LITES are RGB panels, have a CRI and TLCI over 95 and offer bluetooth connection to adjust them with the free Aladdin app right from your phone. The MOSAIC plug connection allows you to use gear like the MOSAIC Wired Dimmer (M-WDIM). The dimmer with display offers you physical dialing, a DMX port and built-in Lumenradio. For each MOSAIC size there is a fitting frame with softbox and grid, like you already know from the FABRIC-LITE. More additional accessories for the MOSAIC-LITES are expected for later this year.

For the MOSAIC-LITES we are introducing the fast changable LED compounds. They allow to replace small LED parts on your panel, without replacing the whole panel. You can either let it get fixed by one of our certified dealers or if you need a faster replacement and have the technical skill to do so, you can do it by yourself. We are providing a step by step tutorial video on how to change the LED compounds at home.



Product Catalog 2022

MOSAIC 4X4

	60cm/2ft	1m/3ft	2m/6ft	3m/9ft	CRI
Daylight 6290K	25400lux	13200lux	4330lux	2210lux	95
Tungsten 2750K	31000lux	15800lux	5190lux	2660lux	95

Specifications

Light Source	Super High CRI Power LED's 600W RGBWW
CRI	CRI 95
Beam Angle	140°
Dimmer	Dimming: 0%–100% (1% resolution)
Cooling	passive cooling
Size	112cm x 112cm
DMX	DMX / LumenRadio / Bluetooth
Input	AC/DC 100-240V / 48V



Aladdin MOSAIC 3X6



About Mosaic 3X6

The new Aladdin MOSAIC-LITES are the result of years of customer feedback, engineering and perfecting a flexible LED panel. The results are the probably most perfect LED panels in the industry, available in three sizes. Say hello to the MOSAIC 2X4, 4X4 and 3X6 with RGB from Aladdin Lights.

The MOSAIC-LITES offer new panel sizes you have never seen before from Aladdin Lights. Finally we can happily introduce the long awaited 4X4 (600W) size to you, next to the also new 2X4 (350W) and 3x6 (600W) sizes. Those panels will give you a new advantage on set without any compromise on light quality, weight and flexibility, which you are already used to from Aladdin Lights.

These lights are made for high-end film and photography productions. All MOSAIC-LITES are RGB panels, have a CRI and TLCI over 95 and offer bluetooth connection to adjust them with the free Aladdin app right from your phone. The MOSAIC plug connection allows you to use gear like the MOSAIC Wired Dimmer (M-WDIM). The dimmer with display offers you physical dialing, a DMX port and built-in Lumenradio. For each MOSAIC size there is a fitting frame with softbox and grid, like you already know from the FABRIC-LITE. More additional accessories for the MOSAIC-LITES are expected for later this year.

For the MOSAIC-LITES we are introducing the fast changable LED compounds. They allow to replace small LED parts on your panel, without replacing the whole panel. You can either let it get fixed by one of our certified dealers or if you need a faster replacement and have the technical skill to do so, you can do it by yourself. We are providing a step by step tutorial video on how to change the LED compounds at home.



Product Catalog 2022

MOSAIC 3X6

	60cm/2ft	1m/3ft	2m/6ft	3m/9ft	CRI
Daylight 6290K	18000lux	10600lux	3900lux	2130lux	95
Tungsten 2750K	21800lux	12800lux	4670lux	2540lux	95

Specifications

Light Source	Super High CRI Power LED's 600W RGBWW
CRI	CRI 95
Beam Angle	140°
Dimmer	Dimming: 0%–100% (1% resolution)
Cooling	passive cooling
Size	176cm x 91 cm
DMX	DMX / LumenRadio / Bluetooth
Input	AC/DC 100-240V / 48V



Aladdin ALL-IN LINE



About Mosaic ALL-IN LINE

The new Aladdin MOSAIC-LITES are the result of years of customer feedback, engineering and perfecting a flexible LED panel. The results are the probably most perfect LED panels in the industry, available in three sizes. Say hello to the MOSAIC ALL-IN LINE, 2X4, 4X4 and 3X6 with RGB from Aladdin Lights.

The MOSAIC-LITES offer new panel sizes you have never seen before from Aladdin Lights. Finally we can happily introduce the long awaited 4X4 (600W) size to you, next to the also new 2X4 (350W), ALL-IN LINE (165W) and 3x6 (600W) sizes. Those panels will give you a new advantage on set without any compromise on light quality, weight and flexibility, which you are already used to from Aladdin Lights.

These lights are made for high-end film and photography productions. All MOSAIC-LITES are RGB panels, have a CRI and TLCI over 95 and offer bluetooth connection to adjust them with the free Aladdin app right from your phone. The MOSAIC plug connection allows you to use gear like the MOSAIC Wired Dimmer (M-WDIM). The dimmer with display offers you physical dialing, a DMX port and built-in Lumenradio. For each MOSAIC size there is a fitting frame with softbox and grid, like you already know from the FABRIC-LITE. More additional accessories for the MOSAIC-LITES are expected for later this year.

For the MOSAIC-LITES we are introducing the fast changable LED compounds. They allow to replace small LED parts on your panel, without replacing the whole panel. You can either let it get fixed by one of our certified dealers or if you need a faster replacement and have the technical skill to do so, you can do it by yourself. We are providing a step by step tutorial video on how to change the LED compounds at home.



Product Catalog 2022

ALL-IN LINE

	60cm/2ft	1m/3ft	2m/6ft	3m/9ft	CRI
Daylight 6290K	4980lux	2160lux	666lux	405lux	95
Tungsten 2750K	5790lux	2520lux	769lux	352lux	95

Specifications

Light Source	Super High CRI Power LED's 165W RGBWW
CRI	CRI 95
Beam Angle	140°
Dimmer	Dimming: 0%–100% (1% resolution)
Cooling	passive cooling
Size	88cm x 30cm
DMX	DMX / LumenRadio / Bluetooth
Input	AC/DC 100-240V / 48V



Aladdin ALL-IN 1

About ALL-IN 1

Can you imagine a filmset without LED lights anymore? Probably not. The industry is changing and LED lights became a major deal in the workflow. Most people go for LED lights on their sets and we understand why and how they choose their gear. This is the reason for our endless journey to provide the best LED light sources for the industry. You need just the best of the best and none less. Today is the day we are introducing the brand new Aladdin ALL-IN 1 to you.

The Aladdin ALL-IN 1 is the result of innovation and feedback from the community. By using Aladdin products you are part of the ALL-IN 1 journey and helped us create an ingenious light panel for you. Starting with an incredibly compact built-in dimmer on the back of the panel. Less weight, easier handling and much more solid than previous generations.

You asked for it and we made it possible. Get the most value out of your production with our new RGB lights. Go for either the 1x1 (ALL-IN 1) or 2x1 (ALL-IN 2) panel and give your footage the ultimate cinematographic flair. With the RGB panels in your bag you are prepared for almost every situation you will ever face in your production career. If you prefer to stick with a solid bi-color panel the new series provides a 1x1 and 2x1 bi-color as well.

Next new feature is the app. We know not everything on this planet needs an app. But why not use this technology for something that is predestined for easier and more accessible control. Why not work faster and more precise on set. The new app provides you all controls in the range of your fingers. Dim a light you just installed on the ceiling across the room without even moving away from your spot. Technology is all there and you are free to use it with us.

With motion control we are even going one step further. Trust your feelings and decide for yourself if you want to use it professionally or not. Motion control for the new panels is provided with the app and the optional remote control as well. Control dimming or color temperature with a tilt movement of your hand and get astonishing results with this new kind of workflow.

ALL-IN 1 Color Kit: ALL-1C-KITC



ALL-IN 1

	60cm/2ft	1m/3ft	2m/6ft	3m/9ft	CRI
Daylight 6300K	4320lux	1600lux	400lux	210lux	97
Bi-Color 4200K	4000lux	1450lux	400lux	200lux	97
Tungsten 2900K	3630lux	1400lux	380lux	190lux	98

Specifications

Light Source	Super High CRI Power LED's (50W BI-COLOR / 20W RGB)
CRI	CRI 98
Beam Angle	140°
Dimmer	Dimming: 0%–100% (1% resolution)
Cooling	passive cooling
Output channel	2 Channels / White BI-COLOR 3 Channels / RGB Color
User interface	Motion detection with wheeling button on Bluetooth wireless controller or App on a smartphone Supported iOS and Android
other functions	Use different colors by mixing RGB and Bi-Color Control by wireless motion detection Control by wheeling button on the wireless controller
Support DMX512	Optional with Wired Dimmer or DMX Attachment
Input AC/DC	12V to 15 Volt DC Or 90-240V AC



Aladdin ALL-IN 2

About ALL-IN 2

Can you imagine a filmset without LED lights anymore? Probably not. The industry is changing and LED lights became a major deal in the workflow. Most people go for LED lights on their sets and we understand why and how they choose their gear. This is the reason for our endless journey to provide the best LED light sources for the industry. You need just the best of the best and none less. Today is the day we are introducing the brand new Aladdin ALL-IN 2 to you.

The Aladdin ALL-IN 2 is the result of innovation and feedback from the community. By using Aladdin products you are part of the ALL-IN 2 journey and helped us create an ingenious light panel for you. Starting with an incredibly compact built-in dimmer on the back of the panel. Less weight, easier handling and much more solid than previous generations.

You asked for it and we made it possible. Get the most value out of your production with our new RGB lights. Go for either the 1x1 (ALL-IN 1) or 2x1 (ALL-IN 2) panel and give your footage the ultimate cinematographic flair. With the RGB panels in your bag you are prepared for almost every situation you will ever face in your production career. If you prefer to stick with a solid bi-color panel the new series provides a 1x1 and 2x1 bi-color as well.

Next new feature is the app. We know not everything on this planet needs an app. But why not use this technology for something that is predestined for easier and more accessible control. Why not work faster and more precise on set. The new app provides you all controls in the range of your fingers. Dim a light you just installed on the ceiling across the room without even moving away from your spot. Technology is all there and you are free to use it with us.

With motion control we are even going one step further. Trust your feelings and decide for yourself if you want to use it professionally or not. Motion control for the new panels is provided with the app and the optional remote control as well. Control dimming or color temperature with a tilt movement of your hand and get astonishing results with this new kind of workflow.

ALL-IN 2 Color Kit: [ALL-2C-KITC](#)



ALL-IN 2

	60cm/2ft	1m/3ft	2m/6ft	3m/9ft	CRI
Daylight 6300K	7300lux	2900lux	820lux	405lux	97
Bi-Color 4200K	7050lux	2750lux	750lux	370lux	97
Tungsten 2900K	7030lux	2810lux	780lux	380lux	98

Specifications

Light Source	Super High CRI Power LED's (100W BI-COLOR / 40W RGB)
CRI	CRI 98
Beam Angle	140°
Dimmer	Dimming: 0%–100% (1% resolution)
Cooling	passive cooling
Output channel	2 Channels / White BI-COLOR 3 Channels / RGB Color
User interface	Motion detection with wheeling button on Bluetooth wireless controller Or App on a smartphone (Supported iOS and Android)
other functions	Use different colors by mixing RGB and Bi-Color Control by wireless motion detection Control by wheeling button on the wireless controller
Support DMX512	Optional
Input AC/DC	12V to 15V DC or 90-240V AC



Aladdin WHIP-LITE



About WHIP-LITE

The Aladdin WHIP-LITE is truly unique. It is a flexible 120W bi-color LED light for special use. It's made of the long-lasting Aladdin fabric, that is well-known from the FABRIC-LITE & BI-FABRIC. The dimension of 334 x 17cm (11 x 0.6ft) already indicates, that's no ordinary light.

The WHIP-LITE can for example be hidden in kitchens or behind counters to create incredible light details within a minute. Compared to LED tubes the WHIP-LITE is lightweight and can be rolled for transportation, making it an amazing tool for traveling. Another marvelous application is using the Aladdin WHIP-LITE for uncommonly long reflections in the eye. Create once in a lifetime looks with just one extra light source. The panel can be controlled on the dimmer unit that is attached on the back of the panel, using the free app or with the additional dimmer-unit (not in the kit). Each panel has got several eyelets and velcro on its back, giving you the option to mount it quick and easily.



Product Catalog 2022

WHIP-LITE

	60cm/2ft	1m/3.3ft	2m/6ft	3m/9ft	CRI
Daylight 6300K	2160 lx	1210 lx	519 lx	317 lx	>97
Tungsten 2900K	1570 lx	896 lx	393 lx	257 lx	>98

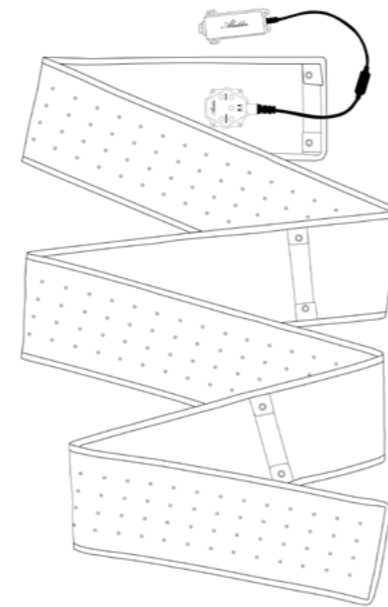

Specifications

Light Source	Super High CRI Power LED's (120W BI-COLOR)
CRI / TLCI	CRI 97 / TLCI 98
Beam Angle	140°
Dimmer	Dimming: 0%–100% (1% resolution)
Color Temperature	2900K - 6100K
Cooling	passive cooling
Dimensions	334 x 17cm x 0.5cm
Input	12-15V DC / 90-240V AC
IP Rating	Panel: IP32 / Wired Dimmer: IP24
Support DMX512	Optional

Aladdin CAPE-LITE

About CAPE LITE

The Aladdin CAPE-LITE is truly incredible. It is a flexible 120W bi-color LED light for special use. It's made of the long-lasting Aladdin fabric, that is well-known from the FABRIC-LITE and BI-FABRIC. The dimension of 170 x 32cm (5.6 x 1ft) already indicates, that's not a basic light.

The CAPE-LITE can for example be hidden in behind counters or in a car to create incredible light details within a minute. Compared to LED tubes the CAPE-LITE is lightweight and can be rolled for transportation, making it an amazing tool for traveling. Another marvelous application is using the Aladdin CAPE-LITE for uncommonly long reflections in the eye. Create once in a lifetime looks with just one extra light source. The panel can be controlled on the dimmer unit that is attached on the back of the panel, using the free app or with the additional dimmer-unit (not in the kit). Each panel has got several eyelets and velcro on its back, giving you the option to mount it quick and easily.



CAPE-LITE

	60cm/2ft	1m/3.3ft	2m/6.6ft	3m/9.9ft	CRI
Daylight 6100K	4330 lx	1350 lx	703 lx	372 lx	>97
Tungsten 2900K	3280 lx	1710 lx	615 lx	328 lx	>98

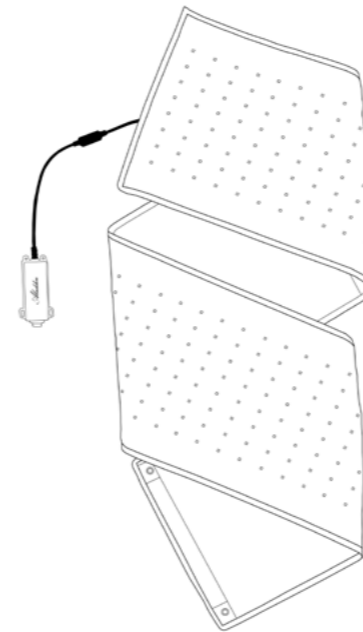

Specifications

Light Source	Super High CRI Power LED's (120W BI-COLOR)
CRI / TLCI	CRI 97 / TLCI 98
Beam Angle	140°
Dimmer	Dimming: 0%–100% (1% resolution)
Color Temperature	2900K - 6100K
Cooling	passive cooling
Dimensions	170 x 32cm x 0.5cm
IP Rating	Panel: IP32 / Wired Dimmer: IP24
Support DMX512	Optional
Input AC/DC	12V to 15V DC Or 90-240V AC

Aladdin FABRIC-LITE 200

About the FABRIC-LITE

The innovative new bi-color FABRIC-LITE, as the name implies, is completely flexible, foldable and offers great flexibility for transport.

Mounting options for the FABRIC-LITE are virtually limitless, including all types of butterfly, overhead, wall and ceiling mounts, thanks to the integrated Velcro and grommets. The 3'x3' panel can be easily mounted on a Matthews frame or similar. Each 3x3-foot fabric panel can be used separately, or combined with others to create panels as large as 12x12 feet. The fixture offers high control over lighting. It is dimmable from 1-100% and the color temperature can be adjusted from 2900°K to 6300°K. The Dimmer runs from main power supply or battery, and has a built-in lumen radio module for DMX control.

FBS200BIKITV



In the box

1x FABRIC-LITE 200

1x Dimmer

1x Pouch for LED Panel

1x Power supply 100V-240V

2x Extension cable

1x Diffusor



Product Catalog 2022

Aladdin



Specifications

Light Source	Super High CRI Power LED's 200W
CRI	CRI 98 / TLCI 98
Color Temperature	2900K-6300K
Beam Angle	140°
Dimmer	Dimming: (1%–100%)
Cooling	passive cooling
Dimmer Input	12V to 30V DC
Power Unit	Automatic Voltage 100V to 240V

FABRIC-LITE

	60cm/2ft	1m/3ft	2m/6ft	3m/9ft	CRI
Daylight 6300K	8300lux	4200lux	1300lux	640lux	97
Bi-Color 4200K	9000lux	4500lux	1400lux	700lux	97
Tungsten 2900K	6800lux	3400lux	970lux	520lux	98



FBS200BI



FBS2035BIFBAG



FBS2035BIBAG



FBS2035FR

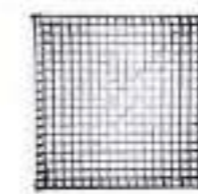

FBS2035GRID



FBS2035DF



BUNGEEBALLPACK



FB200BIDIMVM

Aladdin FABRIC-LITE 350

About the FABRIC-LITE

The innovative new bi-color FABRIC-LITE, as the name implies, is completely flexible, foldable and offers great flexibility for transport.

Mounting options for the FABRIC-LITE are virtually limitless, including all types of butterfly, overhead, wall and ceiling mounts, thanks to the integrated Velcro and grommets. The 3'x3' pan can be easily mounted on a Matthews frame or similar. Each 3x3-foot fabric panel can be used separately, or combined with others to create panels as large as 12x12 feet. The fixture offers high control over lighting. It is dimmable from 1-100% and the color temperature can be adjusted from 2900°K to 6300°K. The Dimmer runs from main power supply or battery, and has a built-in lumen radio module for DMX control.

FBS350BIKITVM



In the box

1x FABRIC-LITE 350

1x Dimmer

1x Pouch for LED Panel

2x Power supply 100V-240V

2x Extension cable

1x Diffuser

Product Catalog 2022

Aladdin



Specifications

Light Source	Super High CRI Power LED's 350W
CRI	CRI 97 / TLCI 98
Color Temperature	2900K-6300K
Beam Angle	140°
Dimmer	Dimming: (1%–100%)
Cooling	passive cooling
Dimmer Input	48V
Power Unit	Automatic Voltage 100V to 240V

FABRIC-LITE

	60cm/2ft	1m/3ft	2m/6ft	3m/9ft	CRI
Daylight 6300K	17800lux	8940lux	2670lux	1300lux	96
Bi-Color 4200K	15700lux	7990lux	2340lux	1140lux	97
Tungsten 2900K	15400lux	7910lux	2340lux	1140lux	97



FBS350BI



FBS2035BIFBAG



FBS2035BIBAG



FBS2035FR

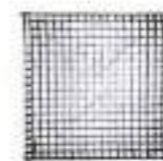

FBS2035GRID



FBS2035DF



BUNGEEBALLPACK



FB350BIDIMVM

Aladdin A-LITE

About the A-LITE

The Aladdin A-LITE is a high-end variable bi-color on-board LED light with an integrated and easy changeable battery. The light quality of the Aladdin A-LITE is outstanding with CRI and TLCI ratings of over 95 for both tungsten and daylight. The integrated lithium-ion battery has a runtime of 1 hour and 20 minutes at full power and can be charged quickly via the included Micro USB-to-USB cable. This USB cable allows you to power and/or charge the A-LITE from any USB charger, laptop, camera or battery with a USB port.

The A-LITE is the slimmest and lightest on-board light on the market and the housing is made from aircraft-grade aluminum. The light comes with a standard 1/4-20" thread to mount to any on-board adapter. A removable hinged, plastic diffuser is included with the light to soften the light even further. The A-LITE produces a color temperature range from tungsten (2900°K) to daylight (6300°K) and every point in between, and is completely dimmable from 5–100%.

In the box

- 1x A-LITE
- 1x Diffusion filter
- 1x USB cable



AMS-08T/D



Product Catalog 2022



Specifications

Light Source	Super High CRI Power LED's (8W)
Beam Angle	140°
Driver	Flicker-Free by CC driver (efficiency>93%)
Switch	Switch: (ON/OFF)
Dimmer	Dimming: (5%–100%)
Color Temperature	2900K–6300K
Battery	3,7V 2,5A Li-ion battery / easy changeable
Housing Material	Aluminium 6061 T6 (Aircraft grade)
Cooling	passive cooling
Dimension	156 x 80 x 11,5 mm
Weight	205 g
Power input	Micro USB 3,6V
Mounting	1/4 Screw

A-LITE

	60cm/2ft	1m/3ft	2m/6ft	3m/9ft	CRI
Daylight 6000K	840lux	230lux	60lux	32lux	92
Bi-Color 4200K	840lux	230lux	60lux	32lux	97
Tungsten 3000K	600lux	170lux	46lux	25lux	97



AMS-02SHOE



AMS-02 14TH



AMS-08DF



AMS-FL40CLAMPPBH



AMS-02-MAG



AMS-08NBAT



AMS-NewSHOE

Aladdin EYE-LITE



About the EYE-LITE

The EYE-LITE (Bi-Color) has two integrated dimmers: one that adjusts color temperature between Tungsten (2900°K) and Daylight (6300°K) and one that controls light output – from 5–100%. The unit has an integrated lithium-ion battery that provides a run-time of over two hours. The housing is made from aircraft aluminum and the quality of the light color is superior to nearly all other daylight LED lights on the market:

- » CRI: 97ra (Tungsten) / 95ra (Daylight)
- » TLCI: 95

Each unit has a standard built-in 1/4" thread for universal mounting and a micro USB plug for charging. The Eye Lite is ideal for many different applications. As the name implies, it's perfect for adding catch-lights in the eyes. Its power and small size allow it to be placed just about anywhere on set (inside furniture, shelves, lamps), as well as in tight spaces (cars, elevators, etc.).

What's included

- EYE-LITE
- Micro USB power supply cable



EYE-LITE Bi-Color AMS-02T/D



Features and Benefits

- Slim, sturdy, lightweight and portable
- Highly quality bi-color output (Daylight/Tungsten)
- Powered by built-in lithium-ion battery or AC adapter
- Flicker-free by CC driver (93% efficiency)
- 100% to 5% dimming with no color shift
- Long-life LEDs

Technical Specifications

- CRI: 97ra
- Color Temperature: Daylight (6300K) / Tungsten (2900K)
- Beam Angle: 140°
- Housing: Aluminum 6061 (aircraft grade)
- Cooling: Air convection

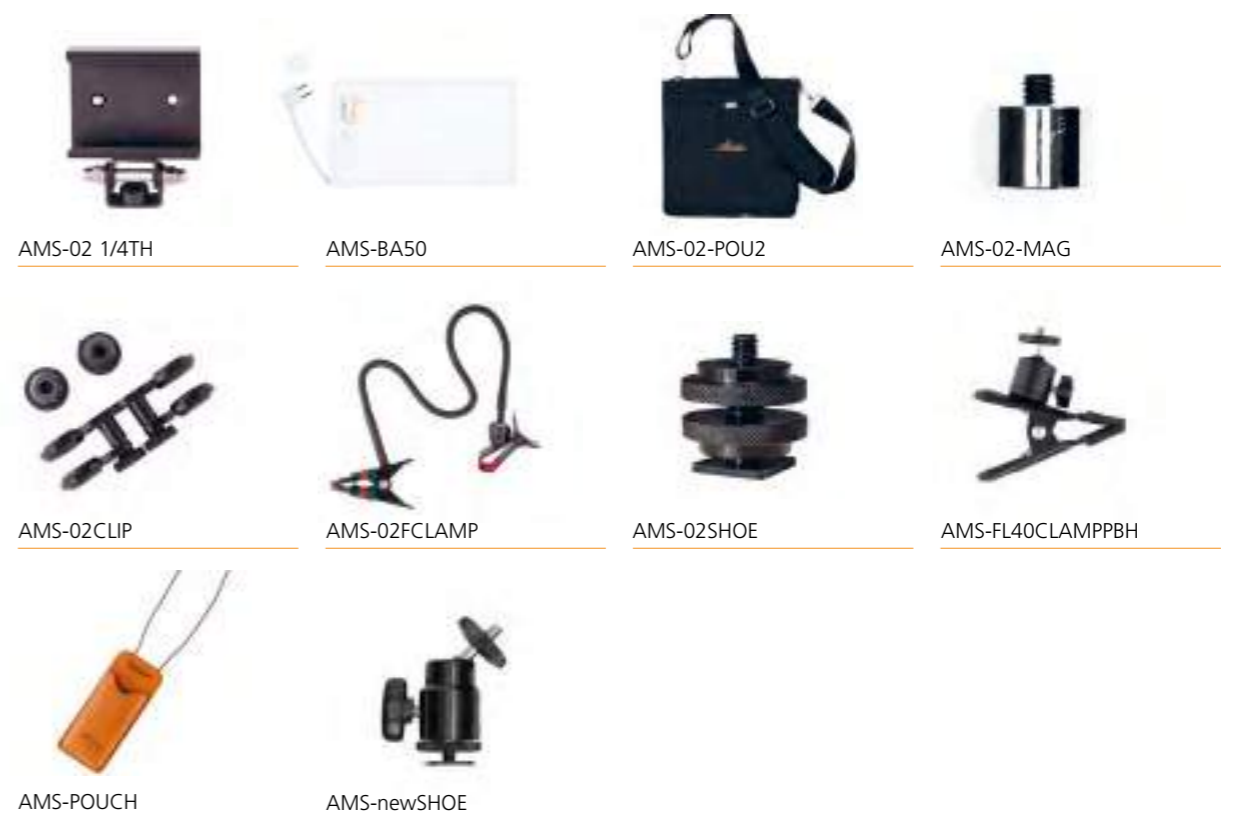

Aladdin BI-FLEX M3

About BI-FLEX M3

The new BI-FLEX M3 (30W) is the cinematographer's dream come true. A small, lightweight and powerful LED light, built with our new micro LEDs.

The 30W BI-FLEX M3 is a 30cm x 12.5cm LED Panel. Its sleek, lightweight design makes this gadget perfect for mobile lighting or studio applications.

With the x-bender you will be able to mount the LED panel on a light stand with a 16mm (5/8) stud. The foldable and lightweight design of the x-bender ensures it will travel light and easy, inside your travel gear. You can mount a diffuser to the x-bender for a softer light.

The Dimmer is Universal up to 70W and runs from main power supply or battery. You can use different sizes of panels with the same dimmer. The two control knobs on the dimmer give you full control over color temperature and intensity.

With the optional DMX module that can be attached to the dimmer, you are ready for a remote application. With this module it will be easy to control the color and intensity of the LED light through your 512 DMX protocol.

In the box

1x BI-FLEX M3

1x Dimmer

1x Stand-Mount

1x Power supply 100V-240V

2x Extension cable

1x Diffusor

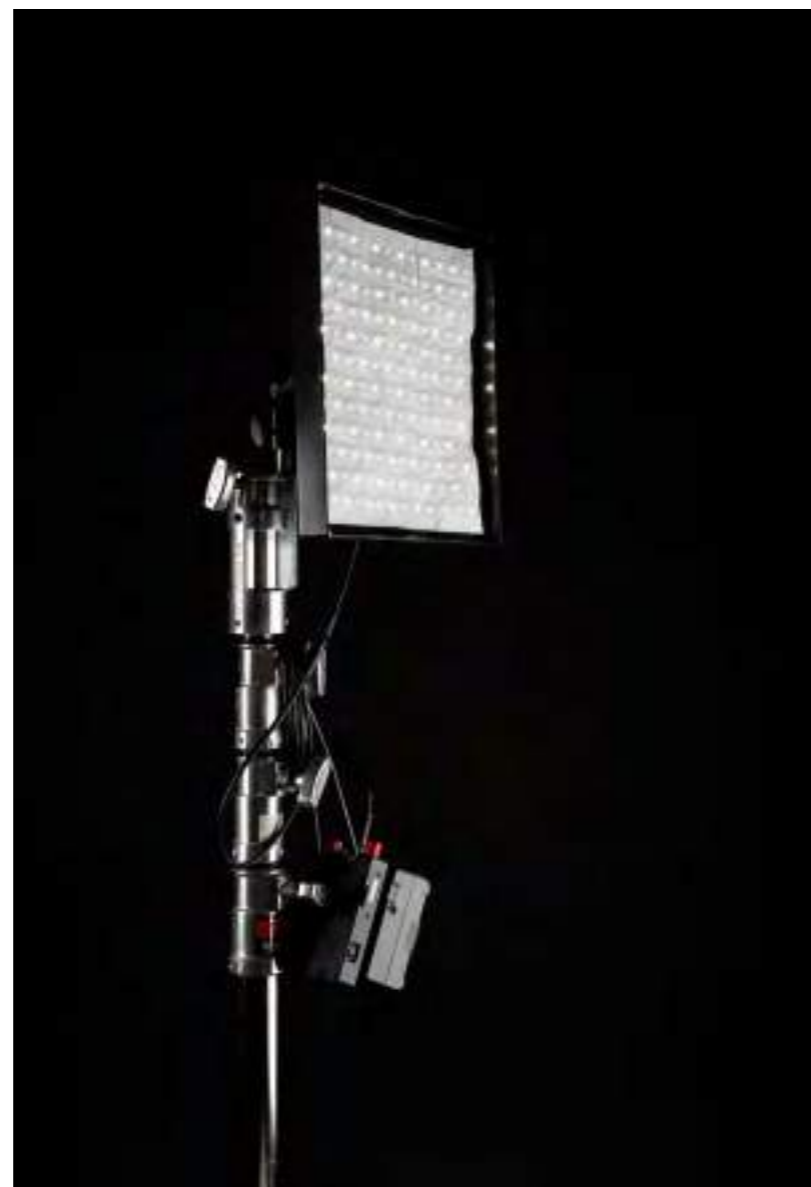

Specifications

Light Source	Super High CRI Power LED's 30W
CRI	CRI 98 / TLCI 98
Color Temperature	2900K-5600K
Beam Angle	140°
Dimmer	Dimming: (1%–100%)
Cooling	passive cooling
Dimmer Input	12V to 30V
Power Unit	Automatic Voltage 100V to 240V

BI-FLEX M3

	60cm/2ft	1m/3ft	2m/6ft	3m/9ft	CRI
Daylight 6300K	2430lux	885lux	250lux	130lux	97
Bi-Color 4200K	2250lux	870lux	240lux	120lux	97
Tungsten 2900K	2170lux	800lux	230lux	120lux	98



MFL357BIDIMVM



MFL 30BI

Aladdin BI-FLEX M7

About BI-FLEX M7

The new BI-FLEX M7 (70W) is the cinematographer's dream come true. A small, lightweight and powerful LED light, built with our new micro LEDs.

The 70W BI-FLEX M7 is a 1'x1'(30x30cm) LED Panel. Its sleek, lightweight design makes this gadget perfect for mobile lighting or studio applications.

With the x-bender you will be able to mount the LED panel on a light stand with a 16mm (5/8) stud. The foldable and lightweight design of the x-bender ensures it will travel light and easy, inside your travel gear. You can mount a diffuser to the x-bender for a softer light.

The Dimmer is Universal up to 70W and runs from main power supply or battery. You can use different sizes of panels with the same dimmer. The two control knobs on the dimmer give you full control over color temperature and intensity.

With the optional DMX module that can be attached to the dimmer, you are ready for a remote application. With this module it will be easy to control the color and intensity of the LED light through your 512 DMX protocol.

For even better light control we offer these accessories:

- Softboxes for soft and even light distribution
- Grids for the softbox for greater precision
- A metal frame for a more solid and rugged hold
- Snoot prevents light spill
- Magnetic holder provides more flexibility in rigging the light.

In the box

1x BI-FLEX M7

1x Dimmer

1x Stand-Mount

1x Power supply 100V-240V

1x Extension cable

1x Diffusor



MFL357BIDIMVM



MFL 70BI



Specifications

Light Source	Super High CRI Power LED's 70W
CRI	CRI 98 / TLCI 98
Color Temperature	2900K-5600K
Beam Angle	140°
Dimmer	Dimming: (1%–100%)
Cooling	passive cooling
Dimmer Input	12V to 30V
Power Unit	Automatic Voltage 100V to 240V

BI-FLEX M7

	60cm/2ft	1m/3ft	2m/6ft	3m/9ft	CRI
Daylight 6300K	5100lux	1900lux	520lux	260lux	97
Bi-Color 4200K	4900lux	1810lux	500lux	250lux	97
Tungsten 2900K	4460lux	1660lux	460lux	225lux	98

Aladdin BI-FABRIC 2

About BI-FABRIC 2

The BI-FABRIC 2 is a flexible Bi-Color LED panel for professional use in television, cinematographic and photographic production with an outstanding light quality. With a CRI and TLCI over 97, the quality of color rendition is outstanding. It is the cinematographer's choice for a small, lightweight and powerful lighting tool for many applications like: Portable interview light or to hide in narrow spaces like elevators, cars or even inside objects for product photography.

The BI-FABRIC 2 runs from mains power supply or batteries. The light comes with a dimmer and a mount for 16mm studs, to mount it onto your stands or clamps and it has on each corner a velcro enabling you to put it where ever you like, for instance to upgrade your old halogen softbox to LED. The BI-FABRIC 2 is a flexible panel light and measures 30x60cm. It's less than 5mm thick and weights only 450g.

In the box

1 x BI-FABRIC 2

1 x Dimmer with V-Mount Adapter and DMX

1 x Power Supply 90V-260V

1 x Extension Cable 5m

1 x Diffuser

1 x X-Bend Holder

1 x Ballhead



FB-2BI-SYSTEM



Specifications

Light Source	Super High CRI Power LED's (100W)
CRI / TLCI	CRI 97 / TLCI 98
Color Temperature	2900K – 6400K
Beam Angle	140°
Dimmer	Dimming: (1%–100%)
Cooling	passive cooling
Dimensions	600 x 300 x 5 mm
Panel Weight	450g
Dimmer Input	12V to 30V
Power Unit	Automatic Voltage 90V–260V
Certification	CE TÜV GS UL

Photometrics

Aladdin BI-FABRIC 2 | 100W

	60cm/2ft	1m/3.3ft	2m/6.6ft	3m/9.9ft	CRI
Daylight 6000K	5780lux	2350lux	685lux	337lux	97
Tungsten 3200K	5160lux	2040lux	582lux	283lux	97



BAG1x2



FL12BIEXCA5M



AMS-FL50BHAD



FB200BIDIMVM



AMS-FL100BISBX

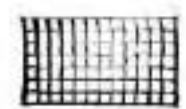

AMS-FL100BIGRID

Aladdin BI-FABRIC 4

About BI-FABRIC 4

The new BI-FABRIC 4 is an exceptionally well-built, bi-color LED light with superior light output and quality. The color output is adjustable from tungsten to daylight and every point in between, and is completely dimmable from 100% to 1%. Most importantly, the light quality is the best available.

The BI-FABRIC 4 panel, at 48"x12" weighs only 2 pounds! This kit includes a professional-grade dimmer with a battery plate built in (V-Lock or A/B Gold Mount) and DMX controls, and an extension cable.

Working with high CRI bi-color light essentially means there is no need to color correction or warming gels (CTO). If you're shooting a portrait with the light set to full daylight and want to add a touch of warmth for improved skin tone, it's just a turn of a dial.

If you're working in tight quarters and there's no room for a stand, that's no problem, as you have several other mounting options. Every BI-FABRIC panel has both male Velcro corners and mounting rings, which means you can mount to any surface using female Velcro, screws, nails or even suction cups. And of course, if it's easier, you can simply gaff-tape the panel to walls, ceilings or poles.

Working with the BI-FABRIC is not like working with any other light. Because it is highly portable, throws beautiful variable light, can be mounted just about anywhere, and is easy to use and built to last, it will free you from conventional restrictions and allows for improvement in the quality of your work.

In the box

- 1x BI-FABRIC 4 with Pouch
- 1x Dimmer with V-Mount Adapter and DMX
- 1x Frame with 16mm stud
- 1x Power supply 90V-260V
- 1x Extension cable 5m
- 1x Diffusor



FB-4BI-SYSTEM



Specifications

Light Source	Super High CRI Power LED's (200W)
CRI	over 97
Color Temperature	2900K-6400K
Beam Angle	140°
Dimmer	Dimming: (5%-100%)
Cooling	passive cooling
Dimensions	1080 x 300 x 5 mm
Panel Weight	900g
Dimmer Input	12V to 30V DC
Power Unit	Automatic Voltage 90V-260V AC
Certification	CE TÜV GS UL

Photometrics

Aladdin BI-FABRIC 4 | 200W

	60cm/2ft	1m/3.3ft	2m/6.6ft	3m/9.9ft	CRI
Daylight 6000K	8440lux	3750lux	1100lux	550lux	97
Tungsten 3000K	7170lux	3210lux	972lux	483lux	97



AMS-FL200BIDF



AMS-FL200BIEXCA5M



AMS-FL200BIFR



FL200BIBAG



FB200BIDIMVM





