



# MAXI MIX

## WHAT IS THE MAXI MIX?

- 120 X 36 X 8,5 cm - 47 X 14 X 3.3 "
- 380 W Max Consumption
- 8 kg - 17.6 lb
- 24 TO 35 VDC - *minimum battery load 15 Amp*
- 1700K TO 10000K
- FULL COLOR (MIX TECHNOLOGY)
- TRUE ROSCO COLOR™
- FLICKER FREE
-  RoHS 

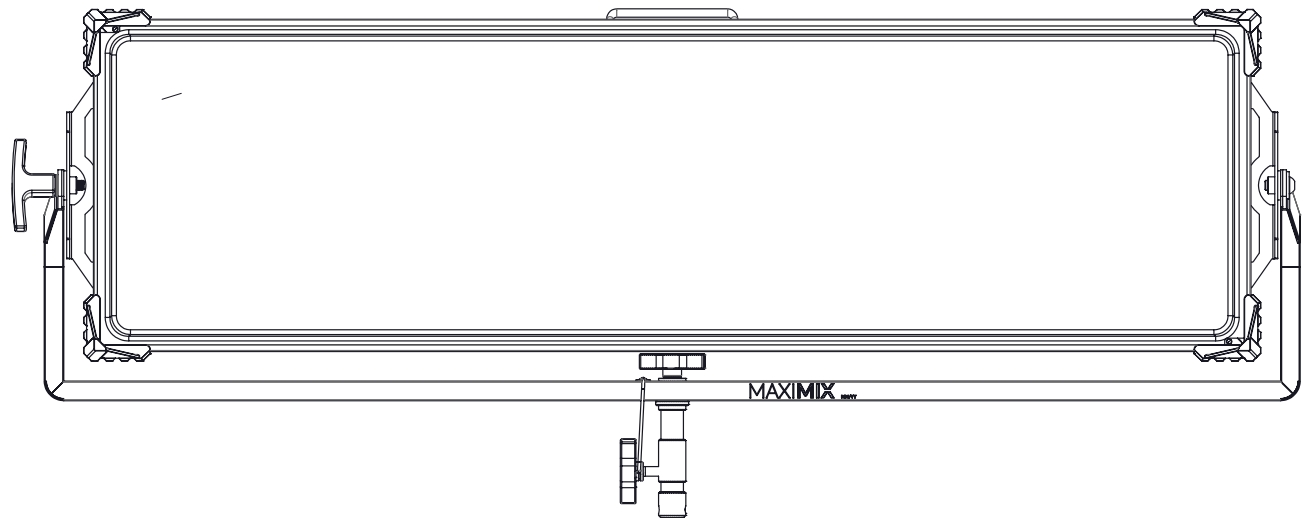

# TABLE OF CONTENT

<b>SAFETY AND PRECAUTIONS</b> .....	03	• <b>BLUETOOTH: BT/OFF</b> 15
<b>ASSEMBLY AND MOUNTING</b> .....	04-07	• <b>DMX MODE</b> 15
<b>MIX CONTROLLER USAGE EXAMPLE</b> .....	08	• <b>DIMMING CURVE</b> 15
<b>MAXI MIX CONTROLLER</b> .....	09	• <b>GEL SORTING</b> 16
<b>MAXI MIX CONTROLLER LOCAL USER INTERFACE</b> .....	10	• <b>RDM (REMOTE DEVICE MANAGEMENT)</b> 16
<b>THE 3 OPERATING MODES: WHITE / GEL / COLOR</b> .....	11	• <b>FACTORY SETTINGS</b> 16
• <b>WHITE MODE</b> 11		• <b>INFORMATION</b> 16
• <b>GEL MODE</b> 11		• <b>ERROR CODES</b> 16
• <b>COLOR MODE</b> 11		• <b>ZONE SELECTION</b> 17
<b>THE SAVE FUNCTION</b> .....	12	<b>COMMUNICATION PROTOCOLS: ARTNET, DMX512 AND THE MYMIX APP</b> ....
• <b>SAVING A PRESET IN MYMIX</b> 12		• <b>DMX 512 WIRED AND WIRELESS</b> 18
• <b>CALLING UP PRESET</b> 12		• <b>BLUETOOTH WITH MYMIX APP</b> 18
• <b>DELETING A PRESET</b> 12		• <b>ARTNET</b> 18
<b>THE LIBRARY AND ITS FOLDERS</b> .....	12-14	<b>SETTING UP DMX AND BLUETOOTH</b> .....
• <b>EFFECTS FOLDER</b> 12		• <b>DMX MODE OVERVIEW</b> 18
• <b>SOURCE MATCHING FOLDER</b> 12		• <b>LINKING AND UNLINKING CRMX</b> 18
• <b>ROSCO GELS FOLDER</b> 13-14		• <b>SETTING UP DMX (WIRED AND WIRELESS)</b> 19
<b>CONTROLLER SETTINGS</b> .....	15-17	• <b>SETTING UP T AND R MODE</b> 19
• <b>MYMIX FOLDER</b> 15		• <b>SETTING UP BLUETOOTH WITH MYMIX APP</b> 19
		• <b>SETTING UP ARTNET</b> 19
		<b>DMX PROFILES</b> .....
		19-23
		<b>THE MYMIX MOBILE APPLICATION</b> .....
		24-28
		<b>UPDATING THE MIX FIRMWARE</b> .....
		29

## SAFETY AND PRECAUTIONS

### General precautions

- DMG Lumière products are made to be used by trained professionals only.
- DMG Lumière products are not for household use.

### Risk of falling

- All lights must be secured with an appropriate safety system (additionally to the mounting system provided). All lamp heads have security cables attached for this purpose. If not used, there is a high risk of accident, falling or death.
- Make sure the slings or chains chosen to secure the light complies with the security standards in the country you are in.

### Risk of electric shock and fire

- High voltage when using with the powerbox and External power supply !
- Use only the power supplies sold by DMG Lumière to power the lights.
- When inputting 220V or 110V AC current, make sure the power supply is connected to the ground before using.
- Do not open the product. There are no user serviceable parts inside.

### Overheating

- Do not operate the product if the ambient temperature exceeds 40° C.
- Intensive use can cause the surface to become hot .
- Let the product cool down completely before you handle it.
- Do not cover the air vents !

### Intense light

- Do not look at the light directly

### Warnings

- Stage and Studio Use Only
- Dry Location Only
- Hazardous Voltage
- Risk of Electrical Shock
- Disconnect Power Before Servicing
- Not For Residential Use

### Power Cut Safety

- If power is cut inadvertently the controls will turn back on automatically when power is back.
- The controls will always turn back on in the last state it was.
- The last state of controls is automatically saved every three seconds.

### Approvals

#### EU Safety :

- EN 55015:2013
- EN 61547:2009
- EN 61000-3-2:2014
- EN 61000-3-3:2013
- EN 61000-4-2:2009
- EN 61000-4-3:2006+A1:2008+A2:2010
- EN 61000-4-4:2012
- EN 61000-4-5:2006
- EN 61000-4-6:2009
- EN 61000-4-8:2010
- EN 61000-4-11:2004
- EN 62471

#### FCC :

- 47 CFR of part 15

### Certifications

#### ROHS :

- EPA3050B:1996
- EN1122B:2011
- EPA3052:1996
- EPA7196A:1992
- APE3540C:1996
- EPA8270D:2007

### **DANGER!**

#### **Risk of injury or death through epileptic seizure when using the strob effect.**

Do not use the effect near stairways, in corridors or near public exits.

Provide advance notice that strobe lighting is in use. Display advisory notices on the set, at the point of ticket sales, on tickets if possible, in the program, and at the entrance(s) to the venue or studio. Avoid extended periods of continuous flashing, particularly at frequencies of 10 to 20 flashes per second. At flash rates below 5 flashes per second, it is estimated that only 5% of flicker-sensitive persons will be at risk of seizure. Make sure that personnel at the venue are trained in the care of a person who is having an epileptic seizure and able to provide care if necessary.

If strobes are in use and a person has a seizure, switch the strobes off immediately.

Mount strobes as high above head height as practicable.

## MAXI MIX POWER SUPPLY UNIT

Attaching and securing the power supply:

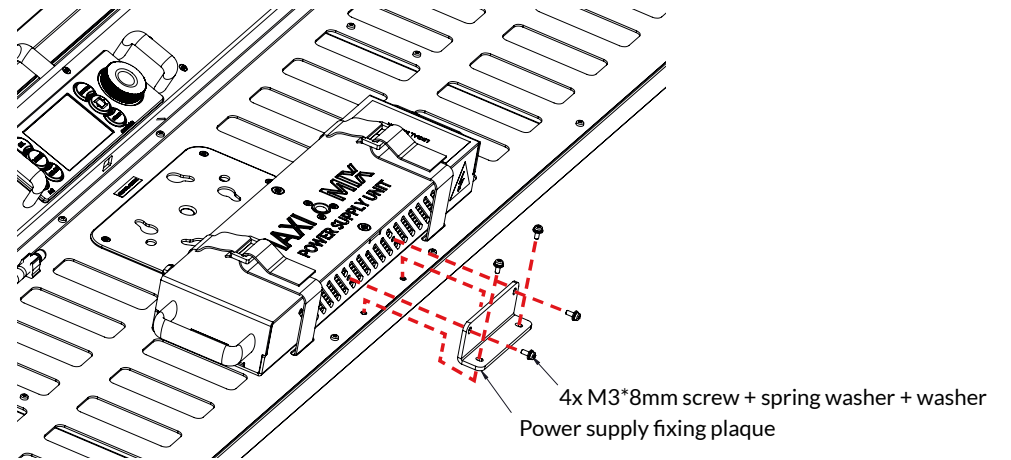
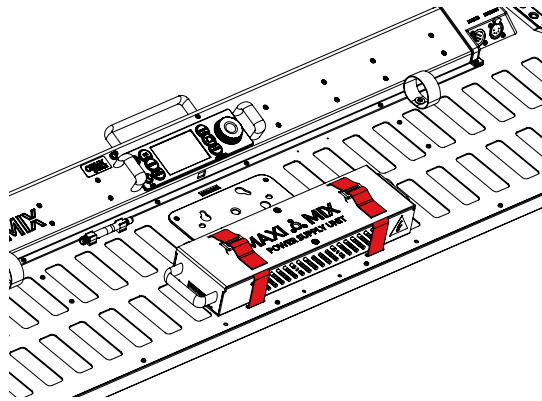
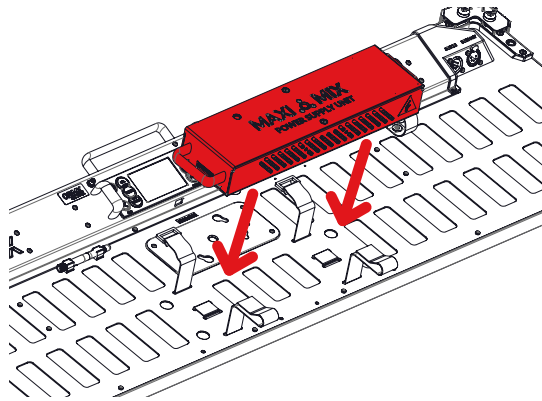

## CORNERS

Remove the corners to access the diffuser.  
Use the provided Allen key.

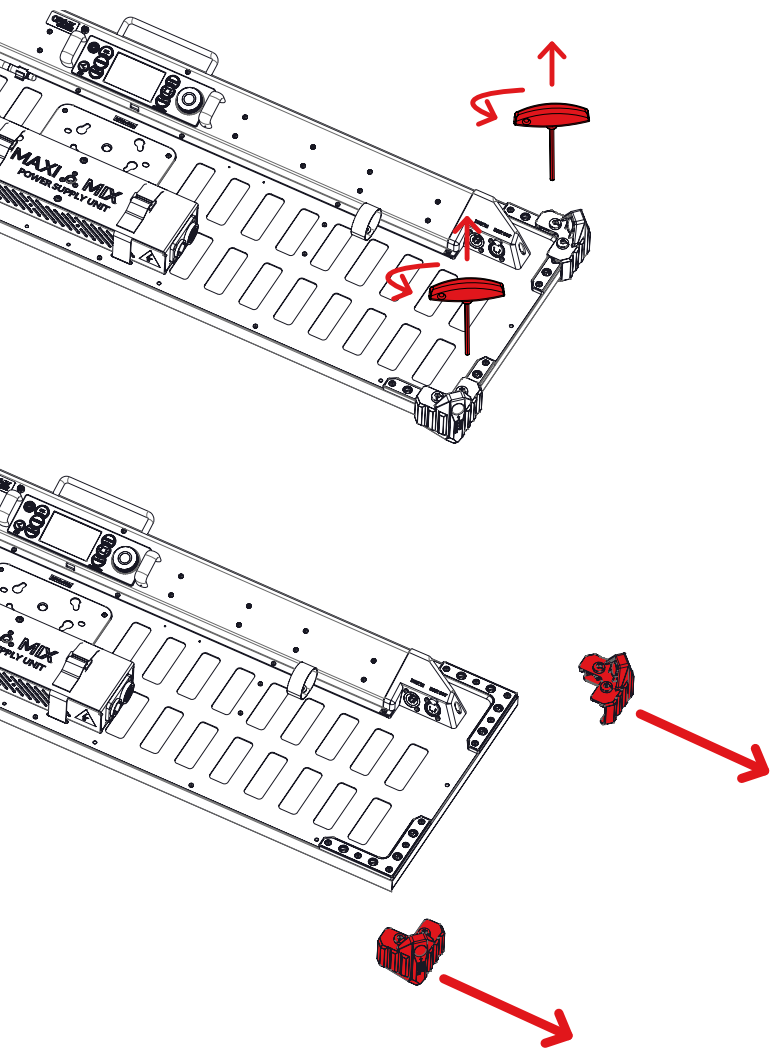

## DIFFUSION

Push the spring-loaded pin to slide the diffuser out.

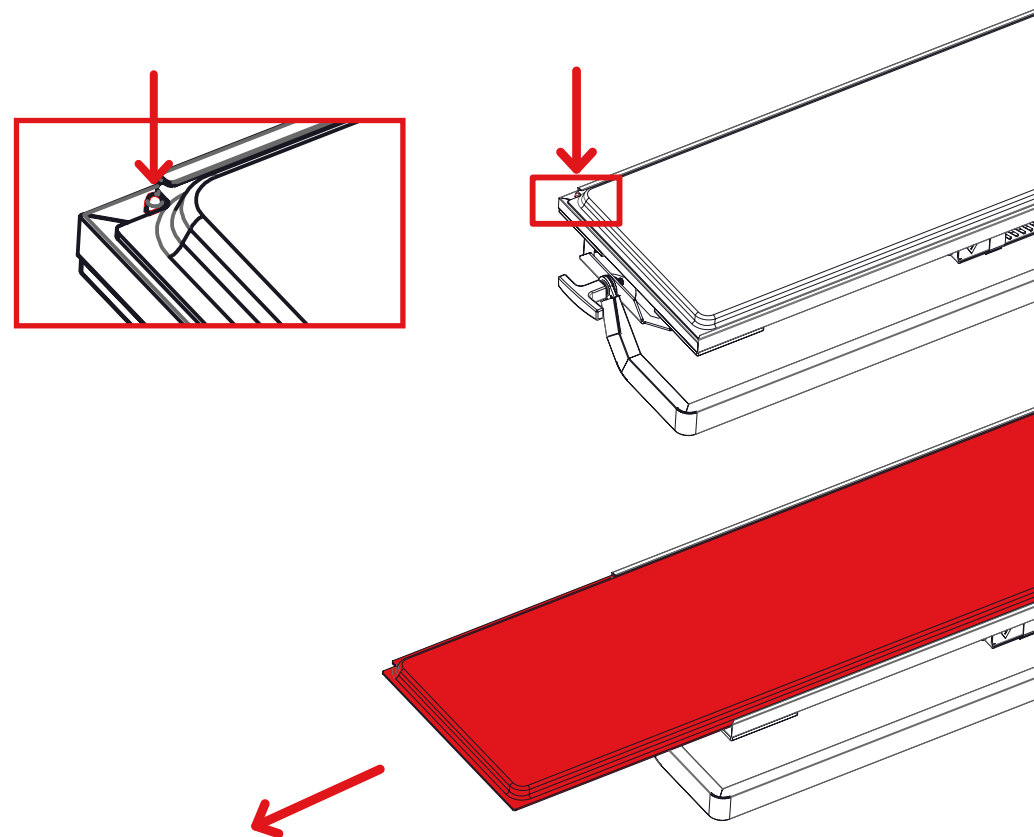

# USER MANUAL - MAXI MIX - ASSEMBLY AND MOUNTING

The 1/4 turn locking system ensures speed with security. Using the Allen Key provided, in a clockwise motion, you will hear a 'CLICK' sound, which verifies the fastener is locked in place. To unlock, repeating the same movement in an anticlockwise motion will unlock the fastener.

WARNING - If you have not heard the fastener 'CLICK', this means it has not been locked safely.

## SIMPLE YOKE

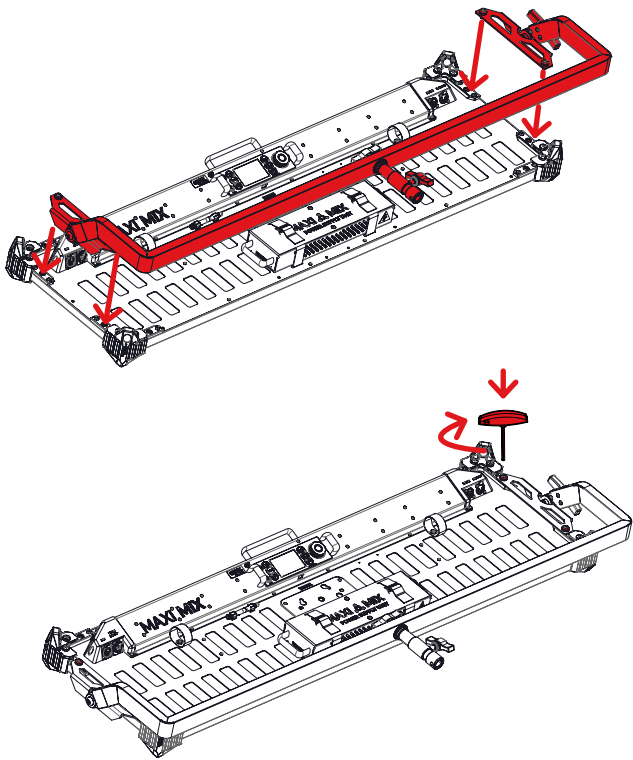

## DOUBLE YOKE

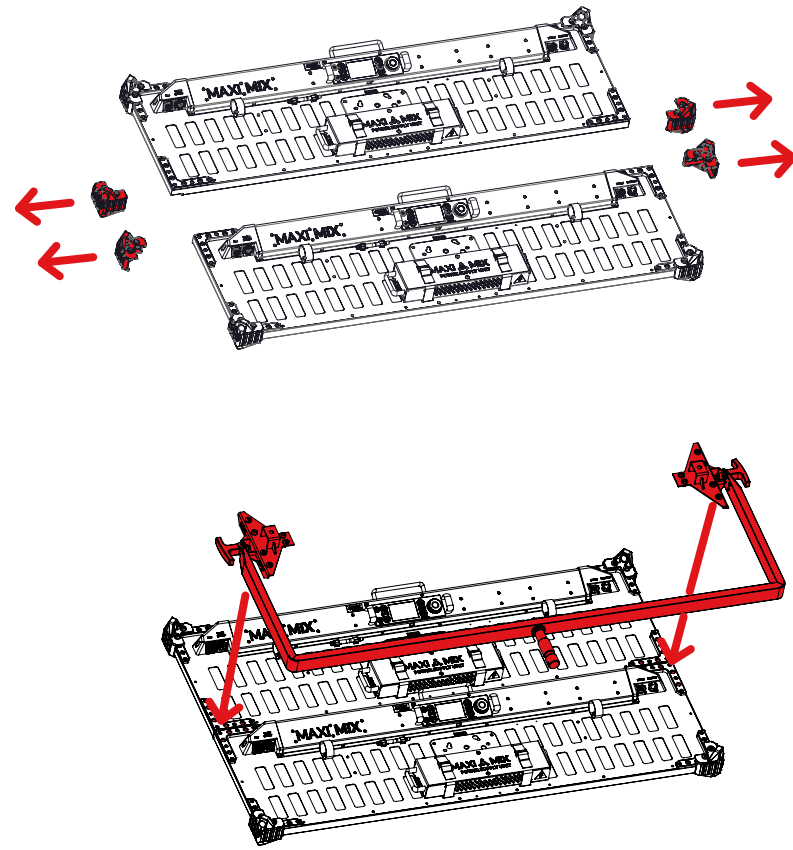

## CORNER RIGGING

Protection corners are designed to enable 4-point rope hanging for specific applications.

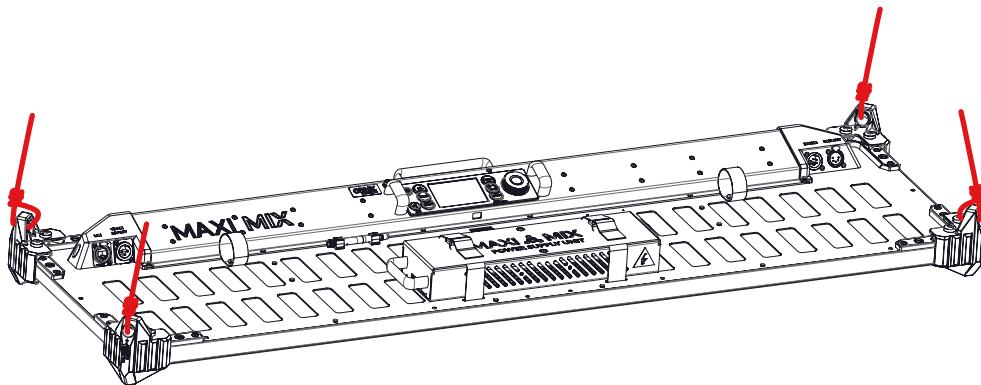

### IMPORTANT NOTICE:

This is not to be used on a double MAXI MIX or any configuration where the LINK2 and LINK4 accessories must be used for hanging.

### IMPORTANT NOTICE 1:

Protection corners are not to be used for safety slings. Always use the handle for security cables.

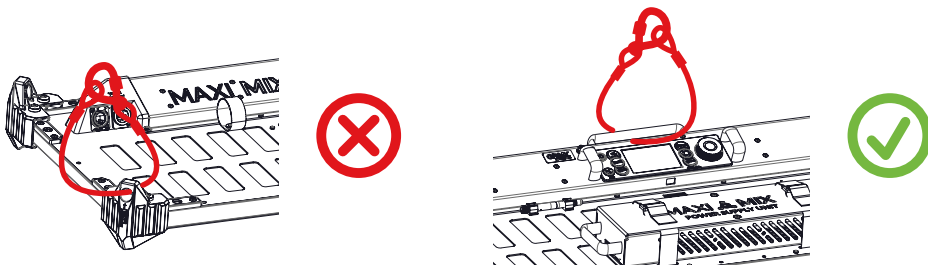

# USER MANUAL - MIX CONTROLLER USAGE EXAMPLE

Our wireless DMX is compatible with any  powered devices.

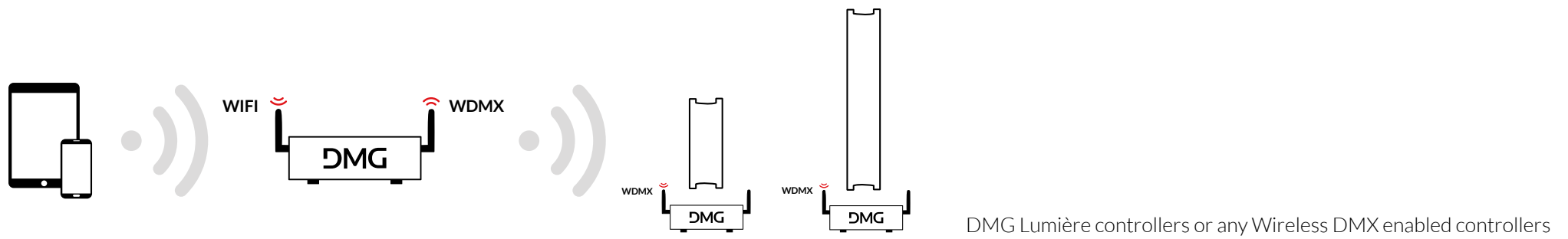
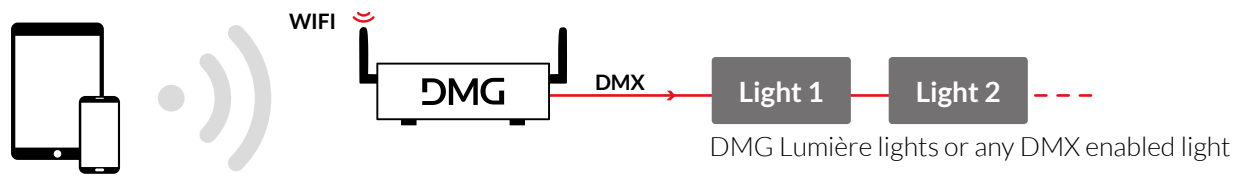
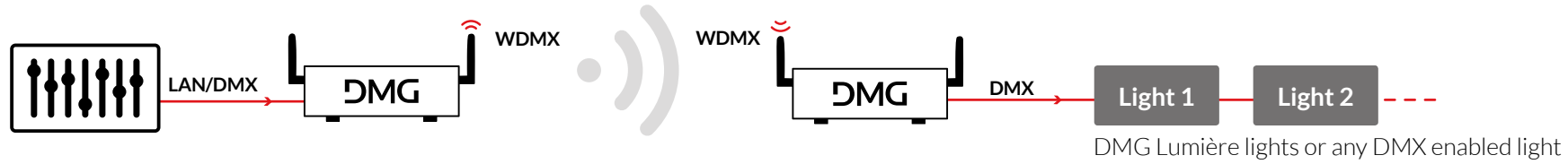

**MYMIX APP IS COMPATIBLE WITH ANY MIX CONTROLLERS.**



# MAXI MIX CONTROLLER

The MAXI MIX controller has the following communication protocols inbuilt:

- › Proprietary "MIX Communication Protocol" via Bluetooth with the myMIX app, up to 14 lights connected at the same time.
- › DMX 512 (with RDM) via XLR-5 or wireless CRMX by LumenRadio (Timo FX transceiver).
- › ArtNet via LAN (RJ45) and WiFi.

The MAXI MIX controller is RDM enabled.  
Built-in micro-USB for upgrades.

✶ 📶 **DMX 512**  lumenradio

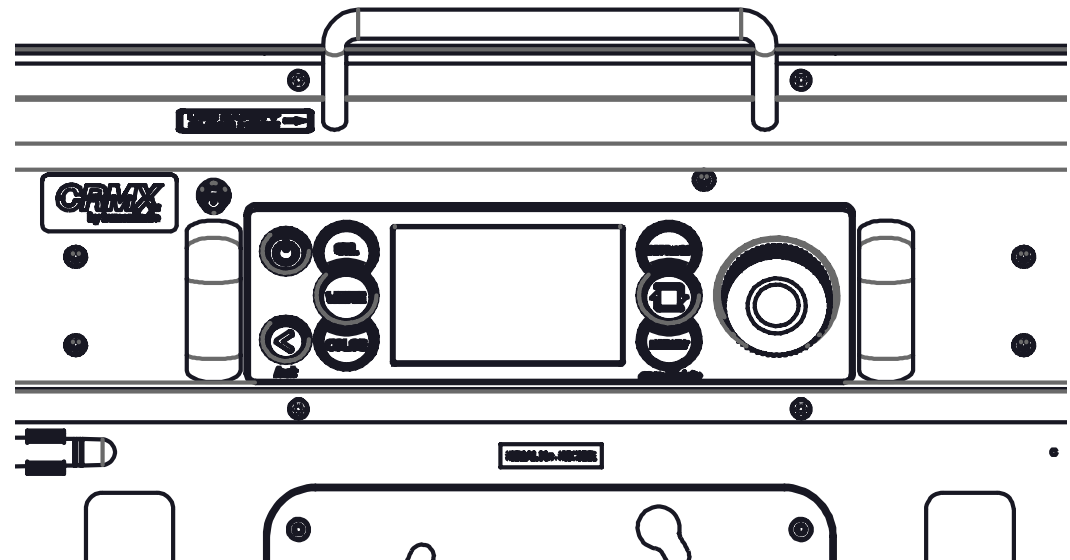

## MAXI MIX CONTROLLER LOCAL USER INTERFACE

### 1. POWER

Turns the fixture ON or OFF.

**Short press:** Turns ON the controls. When ON, a short press will do a quick blackout.

**Long press:** Turn OFF the controls.

### 2. GEL

Sets the light in gel mode. In gel mode you can set the intensity, saturation, white base and hue of the fixture.

**Short press:** Enter gel mode.

**Long press:** No function.

### 3. WHITE

Sets the light in white mode. In white mode you can set the intensity, CCT and Green/Magenta correction of the fixture.

**Short press:** Enter white mode.

**Long press:** No function.

### 4. DISPLAY SCREEN

The display shows the current settings and other information.

### 10. BACK

Back button takes you one step back in menus and locks the fixture controls.

**Short press:** One step back in navigation.

**Long press:** Lock all buttons and the rotary knob. Unlock all buttons and the rotary knob.

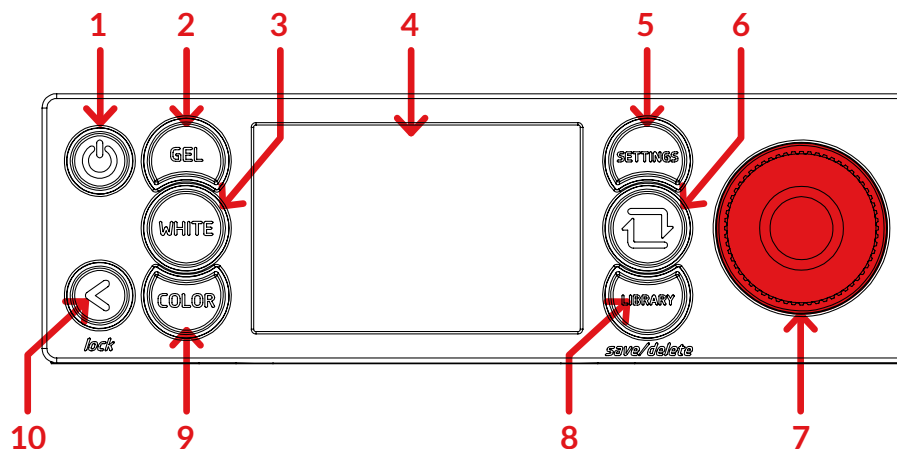

### 8. LIBRARY

Enter the fixture library. All saved presets (white, gels, colors...) are stored here, as well as effects and source match.

**Short press:** Enter the library.

**Long press:** Store a preset when controlling the fixture. Delete a preset when in the library.

### 7. ROTARY KNOB

Use the rotary knob to set values on selected function, as well as to navigate through the menus.

**Short press:** Change between presets when in white, gel and color mode.

**Long press:** No function.

### 6. NAVIGATION

The navigation button allows you to switch from one controllable function to another.

**Short press:** Switch from one controllable function to another.

**Long press:** Link or Unlink the CRMX module (Lumen Radio chip).

### 9. COLOR

Sets the light in color mode. In color mode you can set the intensity, saturation, white base and hue of the fixture.

**Short press:** Enter color mode.

**Long press:** No function.

## THE 3 OPERATING MODES: WHITE / GEL / COLOR

- Use the navigation button to go around the screen functions in each corner of the screen.



- Change values with the dimmer button. Press the dimmer to access presets. Example: Intensity has 4 presets: 25, 50, 75 and 100%.



### • WHITE MODE



Simple CCT mode where you can change the intensity, CCT and Green/Magenta.

Intensity resolution: 0.1%.

CCT range and resolution: 1700k~10000k with a 50k increment.

Green/Magenta range and resolution: full green to full magenta (100G to 100M) with a 1G or 1M increment.

### • GEL MODE



Gel selection mode where you can select any of the gels available in the MIX (standard and saved). Saturation and hue are available on a limited range.

Intensity resolution: 0.1%.

White base: 3200k or 5600k.

Hue range: -10°~+10° (1° increment).

Saturation range: -20%~+20% (1% increment).

### • COLOR MODE



Color selection mode. This mode is an HSI (Hue, Saturation, Intensity) with the ability to select the white base between 1700k and 10000k.

Intensity resolution: 0.1%.

CCT base: 1700k to 10000k.

Hue range: 0°~360° (1° increment).

Saturation range: 0%~100% (1% increment).

## THE SAVE FUNCTION

### • SAVING A PRESET IN MYMIX

To save a preset in myMIX, press the LIBRARY button with a long press until you get prompt the "SAVING PRESET" option. Presets will be saved in the myMIX section. A maximum of **30 presets** can be saved in myMIX.



### • CALLING UP PRESET

To call up a preset enter the Library mode. All your saved presets are stored in myMIX. Presets sent from the myMIX app will also be stored here.



### • DELETING A PRESET

To delete a preset, you must be in LIBRARY/myMIX with a preset selected. Hold down the LIBRARY button with a long press, until you receive a prompt with a 'delete' option. You will be asked to confirm the deletion.



## THE LIBRARY AND ITS FOLDERS

To understand how to use the DMX call up number, go to page 10.

### • EFFECTS FOLDER

Effects selection mode, this is where all effects are stored. To START/STOP the effect, **short press** the ON/OFF button.

TYPE	NAME	DMX CALL UP NUMBER	ROSCO NUMBER	ROSCO SERIE
Effects	Emergency vehicle B	801	N/A	N/A
Effects	Emergency vehicle B+R	802	N/A	N/A
Effects	Emergency vehicle B+W	803	N/A	N/A
Effects	Emergency vehicle R+W	804	N/A	N/A
Effects	Emergency vehicle R	805	N/A	N/A
Effects	Firelight	806	N/A	N/A
Effects	TV screen	807	N/A	N/A
Effects	Paparazzi	808	N/A	N/A



### • SOURCE MATCHING FOLDER

Source matching selection mode, this is where all source match spectrums are stored. This mode emulates standards and legacy sources such as Tungsten, HMI, Sodium vapor... Intensity resolution: 0.1%.

TYPE	NAME	DMX CALL UP NUMBER	ROSCO NUMBER	ROSCO SERIE
Source match	Green screen	701	N/A	N/A
Source match	Blue screen	702	N/A	N/A
Source match	Xenon Headlamp	703	N/A	N/A
Source match	Candle Flame	704	N/A	N/A
Source match	Frosty moonlight	705	N/A	N/A
Source match	HP Sodium	706	N/A	N/A
Source match	LP Sodium	707	N/A	N/A
Source match	Tungsten Domestic	708	N/A	N/A
Source match	Mercury Vapor	709	N/A	N/A
Source match	Sodium Vapor	710	N/A	N/A



## THE LIBRARY AND ITS FOLDERS (CONTINUED)

### • ROSCO GELS FOLDER

TYPE	NAME	DMX CALL UPNUMBER	ROSCO NUMBER	ROSCO SERIE
Gels	Medium Bastard Amber	101	04	Roscolux
Gels	Pale Yellow	102	07	Roscolux
Gels	Pale Amber Gold	103	09	Roscolux
Gels	Straw Tint	104	13	Roscolux
Gels	Flame	105	18	Roscolux
Gels	Sunset Red	106	025	E-Colour
Gels	Pink Carnation	107	039	E-Colour
Gels	Lt Rose Purple	108	47	Roscolux
Gels	Surprise Pink	109	51	Roscolux
Gels	Special Lavender	110	54	Roscolux
Gels	Primary Blue	111	80	Roscolux
Gels	Moss Green	112	089	E-Colour
Gels	Steel Blue	113	117	E-Colour
Gels	Broadway Pink	114	339	Roscolux
Gels	Storaro Orange	115	2002	Roscolux
Gels	Storaro Cyan	116	2005	Roscolux
Gels	Storaro Violet	117	2009	Roscolux
Gels	medium Pink	118	036	E-Colour
Gels	No Color Straw	119	06	Roscolux
Gels	Pale Gold	120	08	Roscolux
Gels	Straw	121	103	E-Colour
Gels	Middle Rose	122	110	E-Colour
Gels	Peacock Blue	123	115	E-Colour
Gels	Light Blue	124	118	E-Colour
Gels	Mauve	125	126	E-Colour
Gels	Bright Pink	126	128	E-Colour
Gels	Golden Amber	127	134	E-Colour

TYPE	NAME	DMX CALL UPNUMBER	ROSCO NUMBER	ROSCO SERIE
Gels	Apricot	128	147	E-Colour
Gels	Pale Gold	129	152	E-Colour
Gels	Pale Salmon	130	153	E-Colour
Gels	Light Amber	131	16	Roscolux
Gels	Bastard Amber	132	162	E-Colour
Gels	Light Flame	133	17	Roscolux
Gels	Pale Bastard Amber	134	302	Roscolux
Gels	Daffodil	135	310	Roscolux
Gels	Mayan Sun	136	318	Roscolux
Gels	Soft Golden Amber	137	321	Roscolux
Gels	Henna Sky	138	325	Roscolux
Gels	No Color Pink	139	33	Roscolux
Gels	Blush Pink	140	333	Roscolux
Gels	Flesh Pink	141	34	Roscolux
Gels	Lighter Blue	142	353	E-Colour
Gels	Blue Bell	143	364	Roscolux
Gels	Pale Rose Pink	144	37	Roscolux
Gels	Cerulean Blue	145	375	Roscolux
Gels	Bermuda Blue	146	376	Roscolux
Gels	Alice Blue	147	378	Roscolux
Gels	Baldassari Blue	148	381	Roscolux
Gels	Skelton Exotic Sangria	149	39	Roscolux
Gels	Salmon	150	41	Roscolux
Gels	Middle Rose	151	44	Roscolux
Gels	Daylight Blue	152	65	Roscolux
Gels	Pale Yellow Green	153	87	Roscolux
Gels	Light Green	154	88	Roscolux

TYPE	NAME	DMX CALL UPNUMBER	ROSCO NUMBER	ROSCO SERIE
Gels	Turquoise	155	92	Roscolux
Gels	Chocolate	156	99	Roscolux
Gels	Rose Pink	157	002	E-Colour
Gels	Lavender Tint	158	003	E-Colour
Gels	Bastard Amber	159	02	Roscolux
Gels	Scarlet	160	024	E-Colour
Gels	Light Amber	161	102	E-Colour
Gels	Light Salmon	162	109	E-Colour
Gels	Fern Green	163	122	E-Colour
Gels	Marine Blue	164	131	E-Colour
Gels	Special Lavender	165	137	E-Colour
Gels	Pale Green	166	138	E-Colour
Gels	Pale Navy Blue	167	143	E-Colour
Gels	Dark Steel Blue	168	174	E-Colour
Gels	Light Red	169	26	Roscolux
Gels	Warm Peach	170	303	Roscolux
Gels	Pale Apricot	171	304	Roscolux
Gels	Rose Gold	172	305	Roscolux
Gels	Gallo Gold	173	316	Roscolux
Gels	Pale Lavender	174	136	E-Colour
Gels	Gypsy Red	175	324	Roscolux
Gels	Shell Pink	176	331	Roscolux
Gels	Cherry Pink	177	332	Roscolux
Gels	Billington Pink	178	336	Roscolux
Gels	True Pink	179	337	Roscolux
Gels	Plum	180	341	E-Colour
Gels	Fushia Pink	181	345	E-Colour

## THE LIBRARY AND ITS FOLDERS (CONTINUED)

TYPE	NAME	DMX CALL UP NUMBER	ROSCO NUMBER	ROSCO SERIE
Gels	Fisher Fuchsia	182	349	Roscolux
Gels	Tipton Blue	183	362	Roscolux
Gels	Cornflower	184	366	E-Colour
Gels	Winkler Blue	185	368	Roscolux
Gels	Sunlight Yellow	186	765	E-Colour
Gels	Lime	187	96	Roscolux
Gels	Medium Purple	188	049	E-Colour
Gels	Mist Blue	189	061	E-Colour
Gels	Lime Green	190	088	E-Colour
Gels	English Rose	191	108	E-Colour
Gels	Dark Pink	192	111	E-Colour
Gels	Leaf Green	193	121	E-Colour
Gels	Smokey Pink	194	127	E-Colour
Gels	Dark Salmon	195	008	E-Colour
Gels	Summer Blue	196	140	E-Colour
Gels	No Color Blue	197	144	E-Colour
Gels	Bright Rose	198	148	E-Colour
Gels	Pink	199	157	E-Colour
Gels	Slate Blue	200	161	E-Colour
Gels	Flame Red	201	164	E-Colour
Gels	Daylight Blue	202	165	E-Colour
Gels	Pale Red	203	166	E-Colour
Gels	Deep Lavender	204	170	E-Colour
Gels	Loving Amber	205	176	E-Colour
Gels	Moonlight Blue	206	183	E-Colour
Gels	Rosy Amber	207	193	E-Colour
Gels	LCT Yellow	208	212	E-Colour

TYPE	NAME	DMX CALL UP NUMBER	ROSCO NUMBER	ROSCO SERIE
Gels	White Flame Green	209	213	E-Colour
Gels	Fluorescent Green	210	219	E-Colour
Gels	Soft Green	211	322	E-Colour
Gels	Jade	212	323	E-Colour
Gels	Follies Pink	213	328	E-Colour
Gels	Violet	214	344	E-Colour
Gels	Waterfront Green	215	504	E-Colour
Gels	Sally Green	216	505	E-Colour
Gels	Marlene	217	506	E-Colour
Gels	Taragon	218	5455	E-Colour
Gels	Grotto Green	219	5461	E-Colour
Gels	Liberty Green	220	730	E-Colour
Gels	Damp Squib	221	733	E-Colour
Gels	Urban Sodium	222	652	E-Colour
Gels	HI Sodium	223	651	E-Colour
Gels	Industry Sodium	224	650	E-Colour
Gels	Wheat	225	763	E-Colour
Gels	Sun Colored Straw	226	764	E-Colour
Gels	Gold Metal	227	550	E-Colour
Gels	1.5 CT Orange	228	286	E-Colour
Gels	Aztec Gold	229	5336	E-Colour
Gels	Bastard Pink	230	779	E-Colour
Gels	Nectarine	231	776	E-Colour
Gels	Cardbox Amber	232	773	E-Colour
Gels	Double CTO	233	287	E-Colour
Gels	Full CTS	234	441	E-Colour
Gels	Half CTS	235	442	E-Colour

TYPE	NAME	DMX CALL UP NUMBER	ROSCO NUMBER	ROSCO SERIE
Gels	Quarter CTS	236	443	E-Colour
Gels	Heighth CTS	237	444	E-Colour

## THE LIBRARY AND ITS FOLDERS (CONTINUED)

### • MYMIX FOLDER

This is your "personal" space, where you can store your favorite colors, whites, gels etc...

Any saved preset will go inside this folder -> long press of the LIBRARY button in any modes: WHITE / GEL / COLOR / EFFECTS / SOURCE MATCH and the preset will go automatically into the myMIX folder.

You can have a maximum of 30 presets into the myMIX folder.

This folder is retrievable into the myMIX app. With the app, you can import the myMIX folder into your mobile device (import FAVORITES), as well as send the presets you have on the app (send to Controller).



## CONTROLLER SETTINGS

### • BLUETOOTH: BT/OFF

BT: Bluetooth is ON, Remote Control is available via Bluetooth and the myMIX app.

Please note that Bluetooth and WI-FI cannot be turned on at the same time. Turning ON Bluetooth will turn off WI-FI and vice versa.



### • DMX MODE

Remote Control is available via Artnet, wired and wireless DMX.

### • DIMMING CURVE

**Linear:** The default curve. The light outputs follow a straight line. 50% on the dimmer equals 50% of the total light, for example.

**Square law:** The light output shares the same pattern that the human eyes perceives. It will feel more realistic (in terms of total light output) to the human eye compared to a linear curve.

**S Curve:** Closer to traditional analog dimmers.

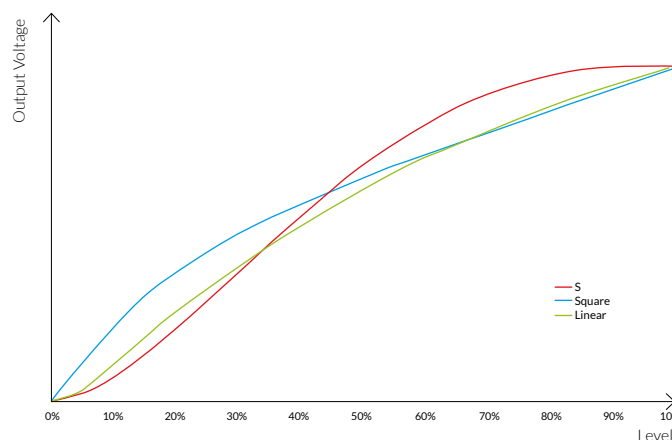

**Tungsten emulated** (only in white mode at 3200k): tungsten emulated curve will change the CCT from 3200k at 100%, to 1700k at 0.1%, emulating the warmer CCT of a dimmed Tungsten light.

## CONTROLLER SETTINGS (CONTINUED)

### • GEL SORTING

Choose how to sort Rosco gels in the library, by name, color or number.

### • RDM (REMOTE DEVICE MANAGEMENT)

MIX is RDM enabled.

It allows MIX light fixtures to send data/settings back to a remote control console (see table below).

Some settings can be changed, others cannot.

RDM table of MIX controller:

CATEGORY	VALUE	MODIFIABLE
MODEL	DMG-MIX	No
MANUFACTURER	DMGLUMIERE (C) 2018	No
DMX START ADDRESS	Example:1	Yes
DMX PERSONALITY (DMX PROFILE)	Example: White 8b	Yes
DMX SLOTS	Example: 4	No
LAMP HEAD TEMP	Example: 50°C	No
CONTROLLER FIRMWARE VERSION	Example: V1.0	No

### • FACTORY SETTINGS

Reset to factory settings, decide to keep or not the content of the myMIX folder.



### • INFORMATION

Serial Number/Firmware Version/Hour Count/Operating Temperature.



For light version :  
Digit 1: LED batch number.  
Digit 2: 1 = MINI ; 2 = SL1, 3 = MAXI.

### • ERROR CODES

ERROR CODE	DESCRIPTION
NONE	No error
ERROR 1	Channel 1 is not working (open circuit, voltage diff,...)
ERROR 2	Channel 2 is not working (open circuit, voltage diff,...)
ERROR 3	Channel 3 is not working (open circuit, voltage diff,...)
ERROR 4	Global Driver Error (All channels affected)
ERROR 5	Temp sensor n°1 can't be read
ERROR 6	Temp sensor n°2 can't be read
ERROR 7	Mem cannot read can't be read



## CONTROLLER SETTINGS (CONTINUED)

### • ZONE SELECTION

The MAXI has 2 independent zones. To select the zone you want to control click on «select zone» and choose the zone you want to control.

This can also be done via the myMIX APP by pressing the 3 dots next to the MAXI MIX name.



## COMMUNICATION PROTOCOLS: ARTNET, DMX512 AND BLUETOOTH WITH myMIX APP

The MIX Controller can be operated remotely via 3 communication protocols:

### • DMX 512 WIRED AND WIRELESS

DMX512 is a worldwide standard communication protocol for the film and entertainment industry.

There are 2 ways to communicate DMX to the MIX controller: wired DMX (XLR 5 pin) or Wireless DMX (Lumen Radio Timo FX RDM).

### • BLUETOOTH WITH MYMIX APP

MIX can be controlled remotely via Bluetooth with the myMIX app. myMIX app can control up to 14 controllers simultaneously. Available on IOS and Android, see page 14.

### • ARTNET

ArtNet is a communication protocol for transmitting the DMX512-A lighting control protocol and Remote Device Management (RDM) protocol over the User Datagram Protocol (UDP) of the Internet Protocol suite. It enables lights to be controlled over standard internet or LAN network (via Wifi or RJ45 connector).

**WARNING:** In DMX mode, when DMX IN is set to WIFI, the Bluetooth (BT) is automatically turned OFF (both WIFI and BT cannot be ON at the same time). If you were connected with the App you will lose connection. To reconnect, turn the Bluetooth back on BT.

## SETTING UP ARTNET, DMX AND BLUETOOTH

To use the MAXI MIX in ArtNet or DMX, go to SETTINGS \ DMX MODE. If you have plugged in a DMX cable, the light will go to DMX mode automatically.



### • DMX MODE OVERVIEW

Select input:

- XLR.
- CMRX (wireless DMX by Lumen Radio).
- LAN (Art-Net).

Select your DMX start address.



Select your profile from the 7 profiles available (refer to user manual for details on the profiles).

Select output:

- XLR.
- CMRX (if input is CMRX you cannot output in CMRX).
- None.

Status of DMX in and out.

**Make sure DMX is enabled.** This is a basic security so local users cannot change to another mode while a board-op is operating the light via DMX.

### • LINKING AND UNLINKING CRMX

- To link receivers when sending CRMX, press the NAVIGATION button for 3 seconds (long press) while the data OUT box is selected (when it is red).
- To unlink receivers when sending CRMX, press the NAVIGATION button for 3 seconds (long press) while the data OUT box is NOT selected (when it is NOT red).
- To unlink CRMX when in receiving mode, press the NAVIGATION button for 3 seconds (long press) while the data IN box is selected (when it is red).

## SETTING UP DMX AND BLUETOOTH (CONTINUED)

### • SETTING UP DMX (WIRED AND WIRELESS)

Input XLR or CRMX (wireless DMX by Lumen Radio).  
Set up the address (check DMX profiles table to enter correct addressing system).  
Enable DMX.

In the library, each preset, gel, source match and effect have a 3-digit DMX number attached to it.

Each DMX digit can be called, using 3 channels.

DMX call up table as below:

0~99: myMIX.

100~699: gels.

700~799: source match.

800~899: effects.

900~999: free space.

Example:

If you would like to call up the GEL 'Mauve', which has a DMX number of 125 (displayed in the LIBRARY and in the myMIX app).

Use the 3 channels dedicated to calling up a preset in your DMX setup:

Channel 1 (hundreds): 0 - 10%= 1.

Channel 2 (tens): 20% - 29%= 2.

Channel 3 (singles): 50% - 59%= 5.

You can then call the preset 125, or «Mauve».

Refer to the table on page 7 or in the myMIX app.

### • SETTING UP T AND R MODE

When 2 MAXIs or more are linked together with Link2 and 4, you can control all of them from on single user interface. To do so, put the controlling MAXI in DATA OUT: T mode and the receiving MAXIs in DATA IN R mode.

MAXIs need to be lined via XLR in order to do this.

Everything done on the transmitting side will be mimiced on the receiving side.

You can also control the transmitter via myMIX, allow for an «infinite» number of MAXIs to be controlled remotly.

### • SETTING UP BLUETOOTH WITH MYMIX APP

To use the MIX in Bluetooth make sure Bluetooth is set to BT in the settings menu:



Bluetooth is ON when set to BT.



Bluetooth symbol should show in white/color/gel.



On the myMIX APP the light's name will be the light's serial number.

### • SETTING UP ARTNET

If you connect to the controller with Wi-Fi, connect to the Wi-Fi network that has the same name as the controller's serial number (ex: MIX-1906-0001).

**Use the following password: dmglumiere**

On the controls: Controller Settings / DMX Mode / Input WIFI or LAN – the controller is ready to receive the ArtNet Protocol.

In ArtNet, you need to broadcast to 2.255.255.255. Subnet 0, universe 0.

## DMX PROFILES

### IMPORTANT INFORMATION:

In profile 3 and 10, only gel memories can be selected.

In profiles 4, 5, 11 and 12, if the memory called is 000, then user has control of the selected function.

Example: if 000 memory is called, then one can use the HUE and SAT mode as on the controller.

## DMX PROFILES (CONTINUED)

### Three basic DMX Profiles replicating the local modes: White/Color/Gel

#	PROFILE NAME	PROFILE DESCRIPTION	CHANNEL 1	CHANNEL 2	CHANNEL 3	CHANNEL 4	CHANNEL 5	CHANNEL 6	CHANNEL 7
1	White mode (same as local)	White 8 bits	Dimming	CCT	Green/Magenta				
2	Color mode (same as local)	Color 8 bits	Dimming	White base color (0~127=3200k 128~255=5600k)	Hue (2° steps)	Saturation			
3	Gel mode (same as local)	Gel 8 bits	Dimming	mem # hundreds	mem # tens	mem # singles	White base gel (0~127=3200k 128~255=5600k)	Hue gel (-10/+10 256/20= number of steps)**	Saturation gel (-20/+20 256/40= number of steps)**

### Four Pro DMX Profiles for ultimate control

#	PROFILE NAME	PROFILE DESCRIPTION	CHANNEL 1	CHANNEL 2	CHANNEL 3	CHANNEL 4	CHANNEL 5	CHANNEL 6	CHANNEL 7
4	All modes in one profile 8bits	Pro 8 bits	Dimming	mem # hundreds	mem # tens	mem # singles	CCT (white base for White mode and Color mode)	Green/Magenta for White mode	Hue (2°)
5	All modes in one profile 16bits	Pro 16 bits	Dimming Coarse	Dimming Fine	mem # hundreds	mem # tens	mem # singles	CCT (white base for White mode and Color mode)	Green/Magenta for white mode
6	Individual control of each LED	Full 8 bits	Dimming	CCT base	G/M	Saturation (cross fade from CCT to a color mix)	Red	Green	Blue
7	Individual control of each LED	Full 16 bits	Dimming Coarse	Dimming Fine	CCT base	G/M	Saturation (cross fade from CCT to a color mix)	Red	Green

### Four Pro DMX Profiles for ultimate control (continued)

#	CHANNEL 8	CHANNEL 9	CHANNEL 10	CHANNEL 11	CHANNEL 12	CHANNEL 13	CHANNEL 14	CHANNEL 15	CHANNEL 16	CHANNEL 17	CHANNEL 18	CHANNEL 19	CHANNEL 20
4	Saturation color 0-100%	White base gel (0~127=3200°K 128~255=5600°K)	Hue gel (-10/+10 256/20 = number of steps)	Saturation gel (-20/+20 256/40 = number of steps)	Effects SPEED	x position	y position	Strobe channel	Control channel				
5	Hue (coarse)	Hue (fine)	Saturation color 0-100%	White base gel (0~127=3200°K 128~255=5600°K)	Hue gel (-10/+10 256/20= number of steps)**	Saturation gel (-20/+20 256/40= number of steps)**	Effects SPEED	x position coarse	x position fine	y position coarse	y position fine	Strobe channel	Control channel
6	White	Amber	Lime	Strob channel	Control channel								
7	Blue	White	Amber	Lime	Strob channel	Control channel							

\*Control Channel: see p22.

## DMX PROFILES FOR TWO SEPARATE ZONES

### Four Pro DMX Profiles for ultimate control with two separate zones

#	PROFILE NAME	PROFILE DESCRIPTION	CHANNEL 1	CHANNEL 2	CHANNEL 3	CHANNEL 4	CHANNEL 5	CHANNEL 6	CHANNEL 7	CHANNEL 8	CHANNEL 9	CHANNEL 10
8	Maxi White mode (same as local)	White 8 bits	Dimming zone 1	CCT zone 1	Green/Magenta zone 1	Dimming zone 2	CCT zone 2	Green/Magenta zone 2				
9	Maxi Color Mode (same as local)	Color 8 bits	Dimming zone 1	White base color zone 1	Hue (2° steps) zone 1	Saturation zone 1	Dimming zone 2	White base color zone 2	Hue (2° steps) zone 2	Saturation zone 2		
10	Maxi Gel Mode (same as local)	Gel 8 bits	Dimming zone 1	mem # hundreds zone 1	mem # tens zone 1	mem # singles zone 1	White base gel zone 1	Hue gel zone 1	Saturation gel zone 1	Dimming zone 2	mem # hundreds zone 2	mem # tens zone 2
11	Maxi All modes in one profile 8bits	Pro 8 bits	Dimming zone 1	mem # hundreds zone 1	mem # tens zone 1	mem # singles zone 1	CCT (white base for white mode and color mode) zone 1	Green/Magenta for white mode zone 1	Hue (2°) zone 1	Saturation color 0-100% zone 1	White base gel zone 1	Hue gel zone 1
12	Maxi All modes in one profile 16bits	Pro 16 bits	Dimming Coarse zone 1	Dimming Fine zone 1	mem # hundreds zone 1	mem # tens zone 1	mem # singles zone 1	CCT (white base for white mode and color mode) zone 1	Green/Magenta for white mode zone 1	Hue (coarse) zone 1	Hue (fine) zone 1	Saturation color 0-100% zone 1
13	Individual control of each LED 8 bits	Full 8 bits	Dimming zone 1	CCTzone 1	G/M	Saturation (cross fade from CCT to a color mix) zone 1	Red zone 1	Green zone 1	Blue zone 1	White zone 1	Amber zone 1	Lime zone 1
14	Individual control of each LED 16bits	Full 16 bits	Dimming coarse zone 1	Dimming fine zone 1	CCTzone 1	G/M	Saturation (cross fade from CCT to a color mix) zone 1	Red zone 1	Green zone 1	Blue zone 1	White zone 1	Amber zone 1

### Four Pro DMX Profiles for ultimate control with two separate zones (continued)

#	CHANNEL 11	CHANNEL 12	CHANNEL 13	CHANNEL 14	CHANNEL 15	CHANNEL 16	CHANNEL 17	CHANNEL 18	CHANNEL 19	CHANNEL 20	CHANNEL 21	CHANNEL 22	CHANNEL 23
10	mem # singles zone 2	White base gel zone 2	Hue gel zone 2	Saturation gel zone 2									
11	Saturation gel zone 1	Effects speed zone 1	x position zone 1	y position zone 1	Strobe channel zone 1	Dimming zone 2	mem # hundreds zone 2	mem # tens zone 2	mem # singles zone 2	CCT (white base for white mode and color mode) zone 2	Green/Magenta for white mode zone 2	Hue (2°) zone 2	Saturation color 0-100% zone 2
12	White base gel zone 1	Hue gel zone 1	Saturation gel zone 1	Effects speed zone 1	x position zone 1	y position zone 1	x position coarse zone 1	Strobe channel zone 1	x position fine zone 1	Dimming Coarse zone 2	Dimming Fine zone 2	mem # hundreds zone 2	mem # tens zone 2
13	Strobe zone 1	Dimming zone 2	CCT zone 2	Saturation (cross fade from CCT to a color mix) zone 2	CCT zone 2	Red zone 2	Green zone 2	Blue zone 2	White zone 2	Amber zone 2	Lime zone 2	Strobe zone 2	cControl channel both zones
14	Lime zone 1	Strobe zone 1	Dimming coarse zone 2	Dimming fine zone 2	CCT zone 2	Saturation (cross fade from CCT to a color mix) zone 2	CCT zone 2	Red zone 2	Green zone 2	Blue zone 2	White zone 2	Amber zone 2	Lime zone 2

## DMX PROFILES FOR TWO SEPARATE ZONES (CONTINUED)

### Four Pro DMX Profiles for ultimate control with two separate zones (continued)

#	PROFILE NAME	PROFILE DESCRIPTION	CHANNEL 24	CHANNEL 25	CHANNEL 26	CHANNEL 27	CHANNEL 28	CHANNEL 29	CHANNEL 30
11	Maxi All modes in one profile 8bits	Pro 8 bits	White base gel zone 2	Hue gel zone 2	Saturation gel zone 2	Effects speed zone 2	x position zone 2	y position zone 2	Strobe channel zone 2
12	Maxi All modes in one profile 16bits	Pro 16 bits	mem # singles zone 2	CCT (white base for white mode and color mode) zone 2	Green/Magenta for white mode zone 2	Hue (coarse) zone 2	Hue (fine) zone 2	Saturation color 0-100% zone 2	White base gel zone 2
13	Individual control of each LED 8 bits	Full 8 bits							
14	Individual control of each LED 16bits	Full 16 bits	sStrobe zone 2	Control channel both zones					

### Four Pro DMX Profiles for ultimate control with two separate zones (continued)

#	CHANNEL 31	CHANNEL 32	CHANNEL 33	CHANNEL 34	CHANNEL 35	CHANNEL 36	CHANNEL 37	CHANNEL 38	CHANNEL 39
11	Control channel zone both zones								
12	Hue gel zone 2	Saturation gel zone 2	Effects speed zone 2	x position coarse zone 2	x position fine zone 2	y position coarse zone 2	y position fine zone 2	Strobe channel zone 2	Control channel zone both zones
13									
14									

## DMX PROFILES (CONTINUED)

\*The control channel:

DMX	FONCTION	DESCRIPTION
0	No fonction	Nothing
11-20	Dim curve linear	Dimmer linear
21-30	Dim curve square	Dimmer square law
31-40	Dim curve s curve	Dimmer in scurve mode
41-50	DIm curve Tungsten	Dimmer in Tungsten emulated
51-60	No fonction	Nothing
61-70	CRMx unlink	Unlink the fixture from a lumenradio transmitter
71-80	CRMx unlink	Unlink the fixture from a lumenradio transmitter
81-90	No fonction	Nothing
91-100	Bluetooth on	Bluetooth on
101-110	Bluetooth off	Bluetooth off
111-120	No fonction	Nothing
121-130	RDM off	Turns off the RDM
131-140	RDM on	Turns on the RDM
141-150	Slew=0	Set slew to 0
151-160	Slew=25 (actual slew)	Set slew to 25 (if 25 is what we have now)
161-170	Save in myMIX	Save current stae in my MIX in the controller

To activate/deactivate a setting, stay 3 seconds on the proposed DMX value. Then, go back to 0.

## THE myMIX MOBILE APPLICATION

The myMIX app is available on [Google store](#) & [App Store](#).

### Connect your light:

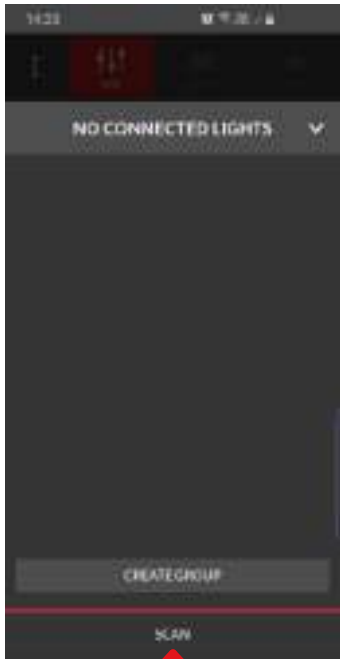

1. Press SCAN to discover MIX lights.



2. Click on a MIX to connect to it.

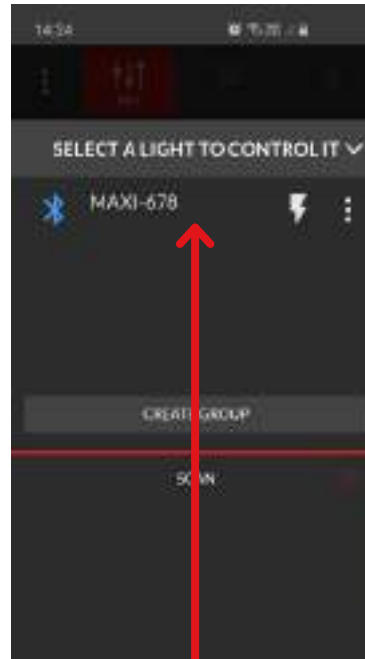

3. Click again on your light to enter live mode.

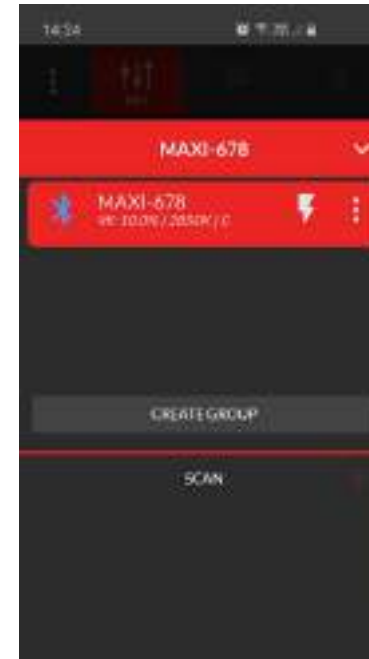

Your light is connected.



## THE MYMIX MOBILE APPLICATION (CONTINUED)

Select the mode:  
WHITE / GEL / COLOR / EFFECTS / SOURCE MATCH



Sensitive touchpad to change values.



Dial in a value with the keyboard.

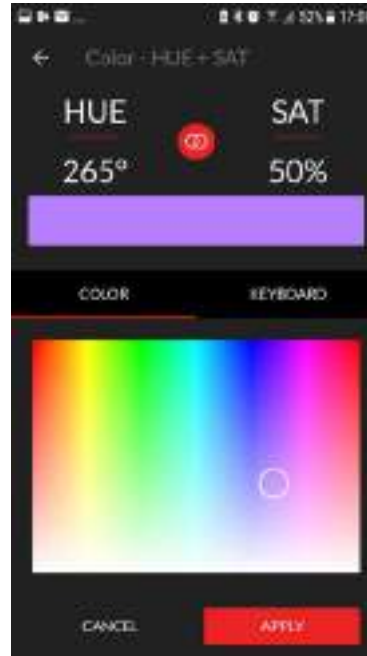

In color mode, use the touchpad for HUE+SAT.

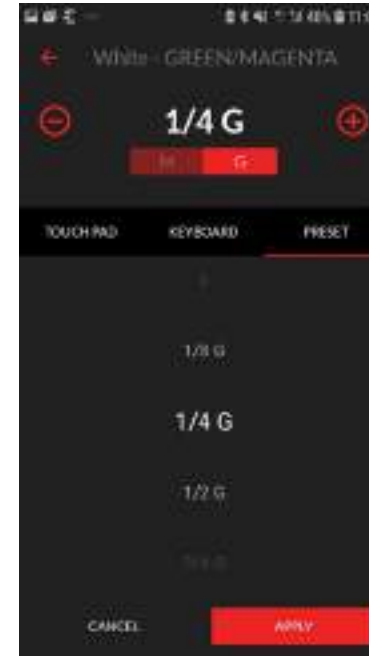

Scroll through presets.

## THE MYMIX MOBILE APPLICATION (CONTINUED)

Your personal library of colors:



Create / Name folders to organise your colors.

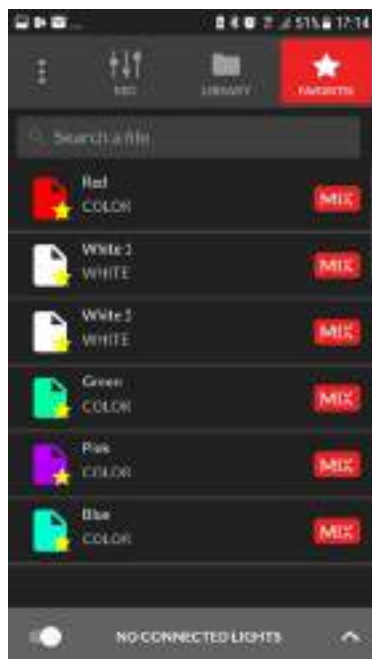

Turn your most used colors into favorite for a quick access.



Touch here to access a wide library of true Rosco color.

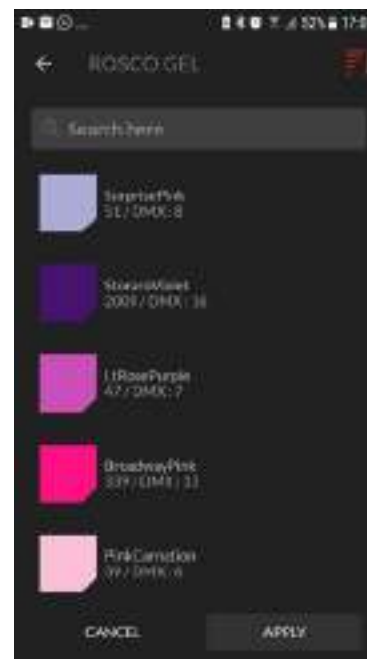

Find your gel, sort the list by name, color or number. The "Apply Gel" button will remove/add the gel.

THE MYMIX MOBILE APPLICATION (CONTINUED)

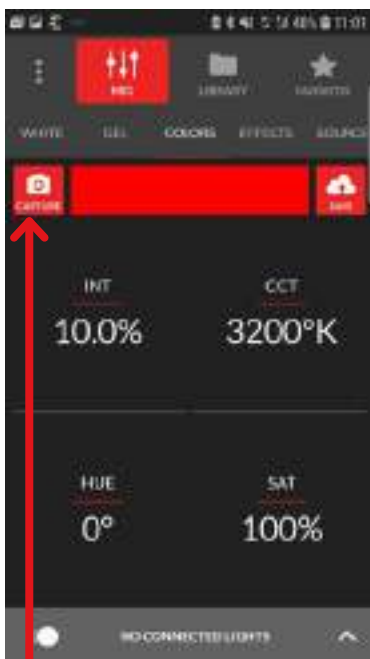

In the color mode, touch the camera to access the CAPTURE function.

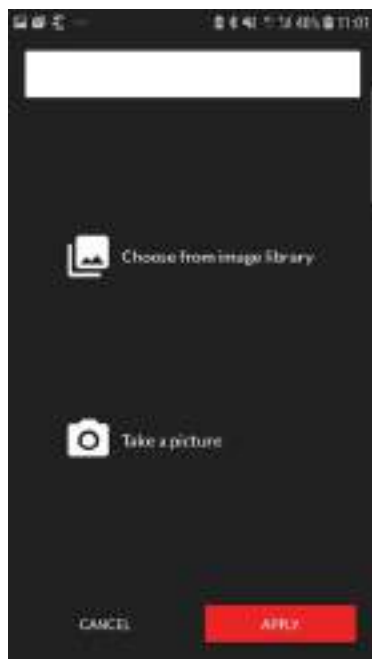

Chose a picture from your gallery or take one, you can then pick the color out of the picture and load it to the light.



Source Match Mode: select the source you want to match and adjust intensity.



Effect Mode: press the PLAY button, select the effect, change speed, intensity and the color of the LEDs.

THE MYMIX MOBILE APPLICATION (CONTINUED)

To control several lights together you must create a group:

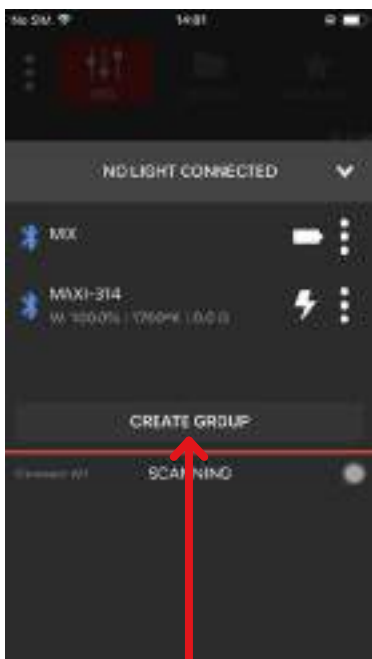

Create a group of lights.

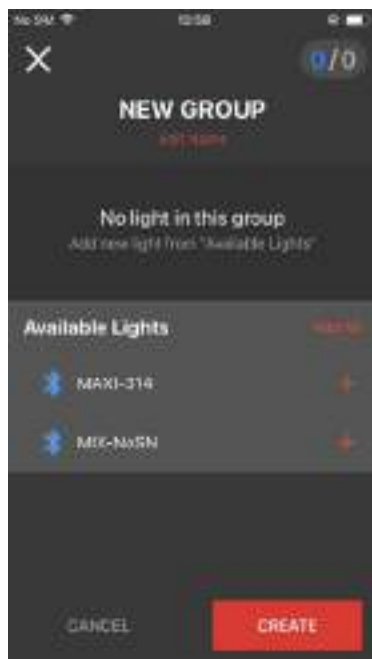

Click the "+" sign to add a light to the group.

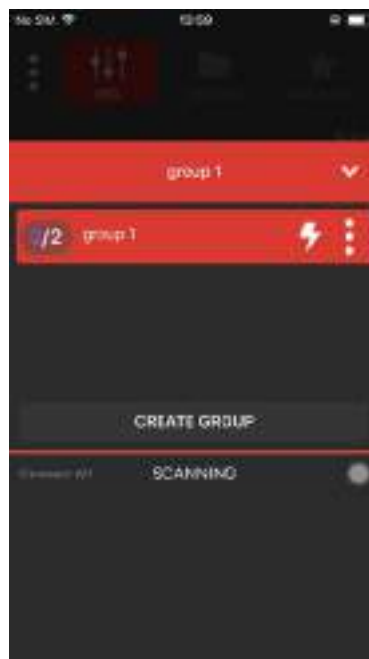

Check if every light of the group is connected.

NEW : the Color xy mode

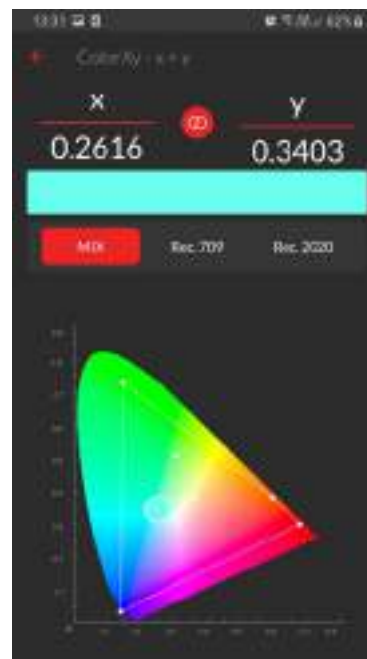

You can select 3 colors spaces on the xy mode: MIX (biggest space possible) REC709 and REC2020.

Select Zone

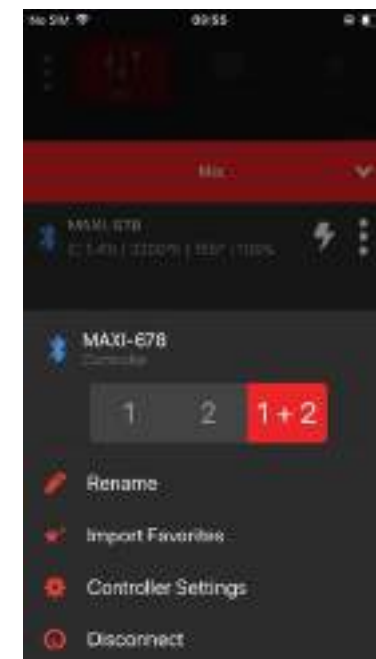

Control your MAXI MIX with precision, by controlling separately the two zones of MAXI panel.

## UPDATING THE MIX FIRMWARE

### • UPDATE YOUR MIX(S) VIA MYMIX

If your MIX controller is not up to date with the latest firmware version, myMIX will prompt you to update. Before updating, please make sure your phone is connected to a power source or has sufficient battery.

Updating one controller will take 10 minutes, 2 controllers 16 minutes, 3 controllers 21 minutes, 4 controllers 27 minutes.

It is not recommended to update more than 4 controllers at a time.

During the update, please make sure your phone is as close a possible to the controllers, and that you do not move around with it.

### • UPDATE YOUR MIX(S) VIA WINDOWS 10

This software is for Windows 10 only.

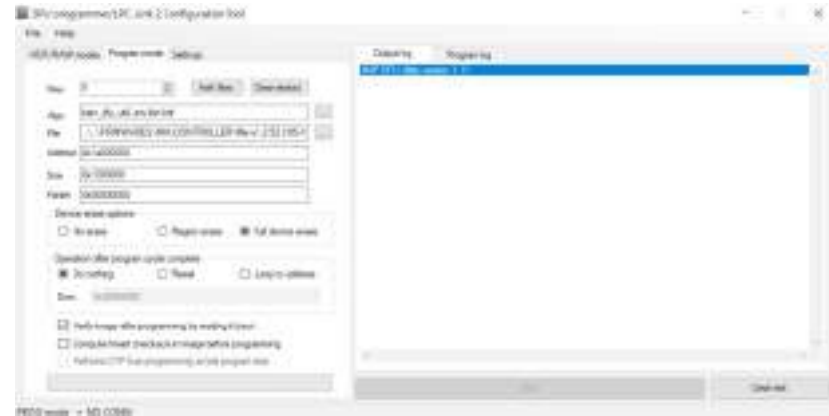

1. Download the update software on [dmglumiere.com](http://dmglumiere.com).
2. Download the latest firmware on [dmglumiere.com](http://dmglumiere.com).
3. Follow the installation instruction.

ENJOY !