

# Kaleido-Alto Kaleido-Quad Multi-Image Display Processor Installation Manual

M791-4200-104

5 September 2008



**Miranda**

**Technologies Inc.**

3499 Douglas-B.-Floreni

St-Laurent, Québec, Canada H4S 1Y6

**Tel. 514-333-1772**

**Fax 514-333-9828**

**[www.miranda.com](http://www.miranda.com)**

© 2008 Miranda Technologies Inc.

## **Safety Compliance Information**

### **Safety Compliance**

This equipment complies with:

- CSA C22.2 No. 60950-1-03 / Safety of Information Technology Equipment, Including Electrical Business Equipment.
- UL 60950-1 (1<sup>st</sup> Edition) / Safety of Information Technology Equipment, Including Electrical Business Equipment.
- IEC 60950-1 (1<sup>st</sup> Edition) Incorporating A1, A2, A3, A4, and A11/ Safety of Information Technology Equipment, Including Electrical Business Equipment.

### **CAUTION**

These servicing instructions are for use by qualified service personnel only. To reduce the risk of electric shock, do not perform any servicing other than that contained in the operating instructions unless you are qualified to do so. Refer all servicing to qualified service personnel. Servicing should be done in a static-free environment.

**Table of Contents**

**1 Kaleido-Alto & Kaleido-Quad ..... 1**

1.1 Introduction ..... 1

1.2 Kaleido-Alto Series: Supports up to 10 Video Inputs ..... 1

1.3 Kaleido-Quad Series: Supports up to 4 Video Inputs ..... 3

**2 Installation ..... 5**

2.1 Unpacking ..... 5

2.2 Mechanical Installation ..... 5

2.3 Power Connection ..... 5

2.4 Signal and Control Connections ..... 5

2.4.1 HD-SDI Video Inputs ..... 6

2.4.2 SD-SDI Video Inputs ..... 7

2.4.3 Composite Video Inputs ..... 7

2.4.4 DVI Input ..... 7

2.4.5 DVI Resolutions Supported with a KXI-DVI-Bridge Connected to the Kaleido's HD-SDI Input ..... 8

2.4.6 Analog Audio Inputs (Optional Alto-SA Mezzanine with 10 or 4 Inputs) ..... 9

2.4.7 Digital Audio Input (Optional Alto-AES Mezzanine) ..... 9

2.4.8 PC Audio Input ..... 10

2.4.9 Component Analog (RGBHV) Output ..... 10

2.4.10 DVI Output ..... 10

2.4.11 Audio Monitoring Output ..... 11

2.4.12 GPI Inputs /Outputs ..... 11

2.4.13 Ethernet ..... 13

2.4.14 USB ..... 13

2.5 Dual power supplies (Optional) ..... 13

2.6 Multiple Kaleido-Alto/Quad Installations ..... 14

2.6.1 Ethernet Connection for use with KEdit ..... 14

2.6.2 Controlling Multiple Kaleido-Alto/Quad units from a Kaleido-RCP ..... 14

**3 Operation ..... 16**

3.1 Powering Up ..... 16

3.2 Front Panel Status LED ..... 16

3.3 Startup and Preparation ..... 16

3.4 Software Installation ..... 16

**4 Technical Specifications ..... 17**

4.1 Inputs ..... 17

4.2 Outputs ..... 18

4.3 Control ..... 19

4.4 Processing Performance ..... 20

4.5 Frame ..... 20

**Annex – Kaleido Display Resolution ..... 21**

**Contact Us! ..... 23**



# 1 Kaleido-Alto & Kaleido-Quad

## 1.1 Introduction

The Kaleido-Alto and Kaleido-Quad multi-image processors can display multiple video inputs (up to 10 for the Alto, up to 4 for the Quad) on a single high-resolution output. The Kaleido-Alto/Quad combines the display of video windows, audio level meters, text identification labels, tallies and on-screen status indicators in a convenient single-RU frame. Various models are offered to support SDI video, composite video or the auto-detection of composite and SDI. Four stereo audio level meters can be displayed inside or outside each video window. Audio sources can be extracted from the embedded audio inside the SDI signals, or input via optional audio mezzanines providing 4 or 10 AES or Analog stereo input signals. A DVI input allows the insertion of an external computer signal to fill the background of the video layout. Layouts can be created using the KEdit layout editor software and applied to the Kaleido-Alto/Quad system afterward. Layouts and frequently-used functions can be operated via the Kaleido-RCP or via a mouse/pointer interface. The Kaleido-Alto/Quad is an ideal solution in areas where a limited number of signals need to be monitored with fine picture quality. Its compact 1RU frame is a real asset in areas where space is restricted.

The Kaleido-Alto/Quad is available in several different models:

## 1.2 Kaleido-Alto Series: Supports up to 10 Video Inputs

### Kaleido-Alto-HD

The Kaleido-Alto-HD is configured with 10 auto-detect HD/SD-SDI/Composite video inputs. Each input is capable of displaying HD/SD-SDI and Composite video input in PAL, SECAM, NTSC or black-and-white formats automatically.

### Kaleido-Alto-AD

The Kaleido-Alto-AD is configured with 10 auto-detect SD-SDI/Composite video inputs. Each input is capable of displaying SD-SDI with 525 or 625 lines and Composite video input in PAL, SECAM, NTSC or black-and-white formats automatically.

### Kaleido-Alto-A

The Kaleido-Alto-A offers 10 Composite inputs. Each input auto-detects PAL, SECAM, NTSC or black-and-white formats.

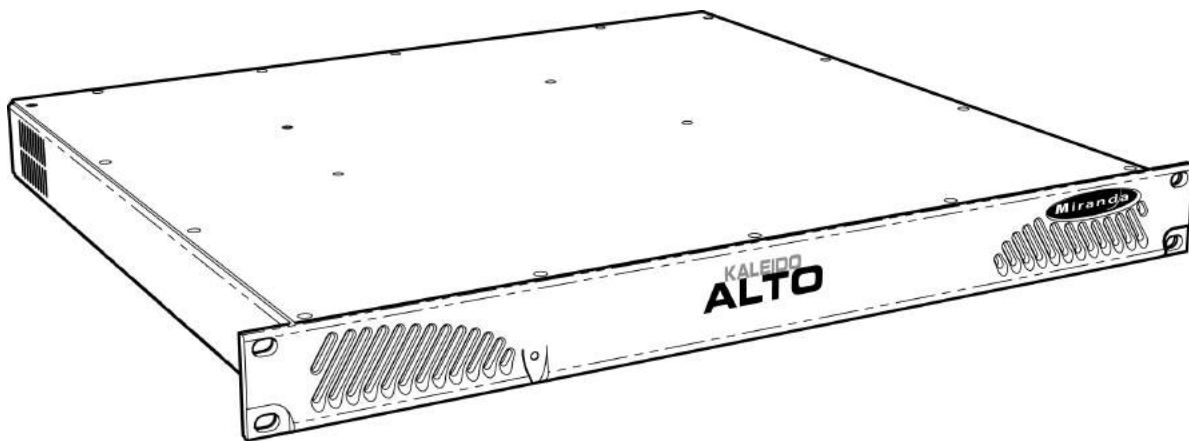

### Kaleido-Alto Features

- Auto-sensing HD-SDI, SDI and Analog Composite inputs (10)
- High-quality DVI and RGBHV outputs with up to 1920 x 1080 pixel resolution (except Kaleido-Alto-A and Kaleido-Alto-AD models, which are limited to 1280 x 1024)
- Embedded, AES and Analog audio level metering with monitoring outputs
- Source IDs, Tallies, clocks (time of day and up/down timers)
- Easy offline layout editing with full choice of window ratio (4:3 and 16:9) and position
- Aspect ratio markers
- Compact (1RU) frame
- Optional redundant power supply
- Optional, simple to use remote control panel

### Kaleido-Alto Configuration

Here is a typical configuration for a Kaleido-Alto, in this case illustrating an Alto-AD.

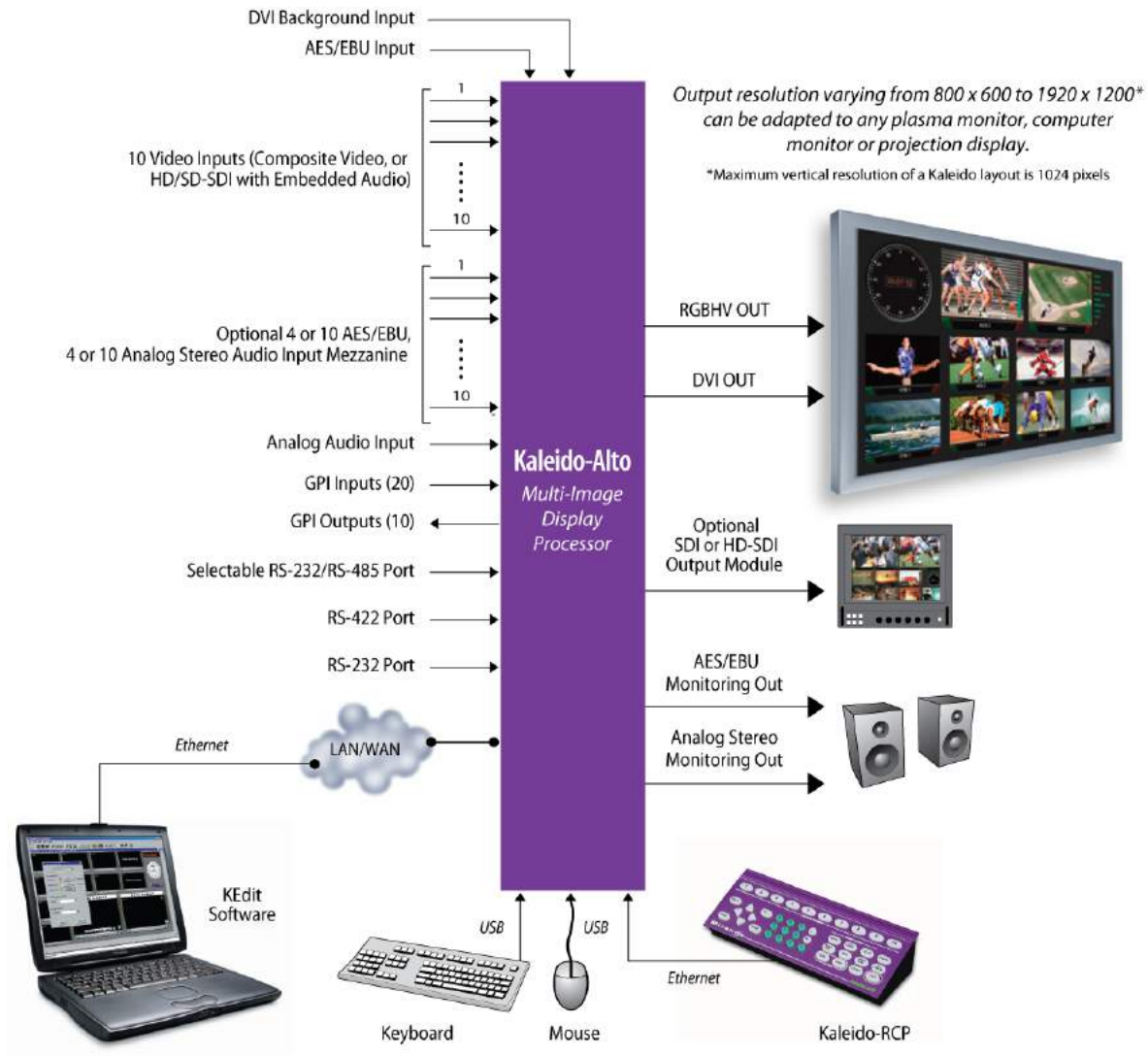

Figure 1.1 Kaleido-Alto-AD configuration

### 1.3 Kaleido-Quad Series: Supports up to 4 Video Inputs

#### Kaleido-Quad-HD

The Kaleido-Quad-HD is configured with 4 auto-detect HD/SD-SDI/Composite video inputs. Each input is capable of displaying HD/SD-SDI and Composite video input in PAL, SECAM, NTSC or black-and-white formats seamlessly.

#### Kaleido-Quad-AD

The Kaleido-Quad-AD is configured with 4 auto-detect SD-SDI/Composite video inputs. Each input is capable of displaying SD-SDI with 525 or 625 lines and Composite video input in PAL, SECAM, NTSC or black-and-white formats seamlessly.

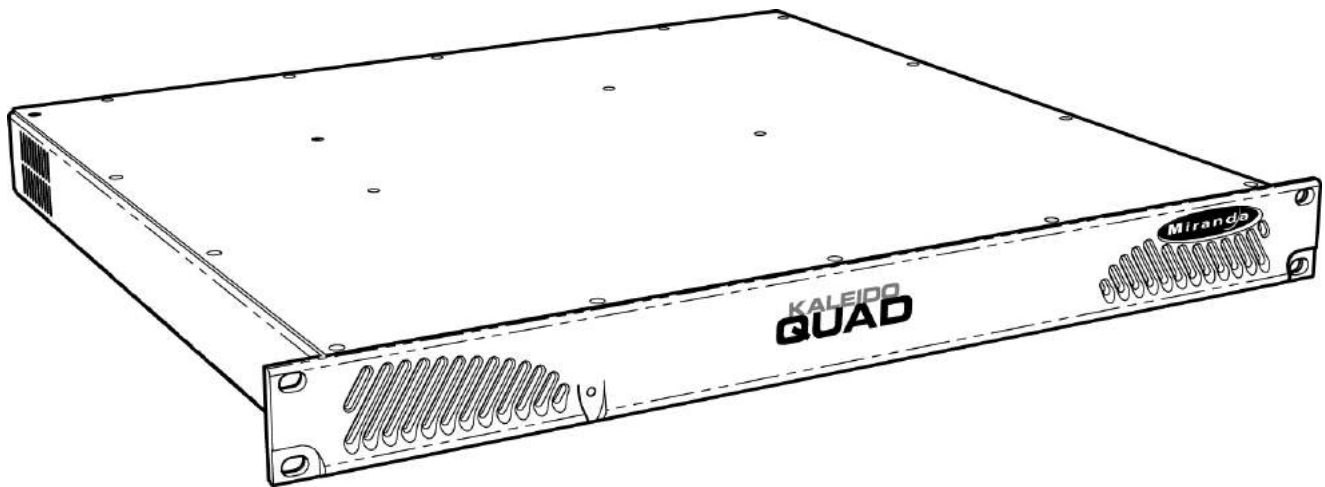

#### Kaleido-Quad Features

- Auto-sensing HD-SDI, SDI and Composite inputs (4)
- High quality DVI and RGBHV outputs with up to 1920 x 1080 pixel resolution
- Embedded, AES and Analog audio level metering with monitoring outputs
- Source IDs, Tallies, clocks (time of day and up/down timers)
- Easy offline layout editing with full choice of window ratio (4:3 and 16:9) and position
- Aspect ratio markers
- Compact (1RU) frame
- Optional redundant power supply
- Optional, simple to use remote control panel

## Kaleido-Quad Configuration

Here is a block diagram showing a typical configuration for a Kaleido-Quad, in this case illustrating a Quad-AD system.

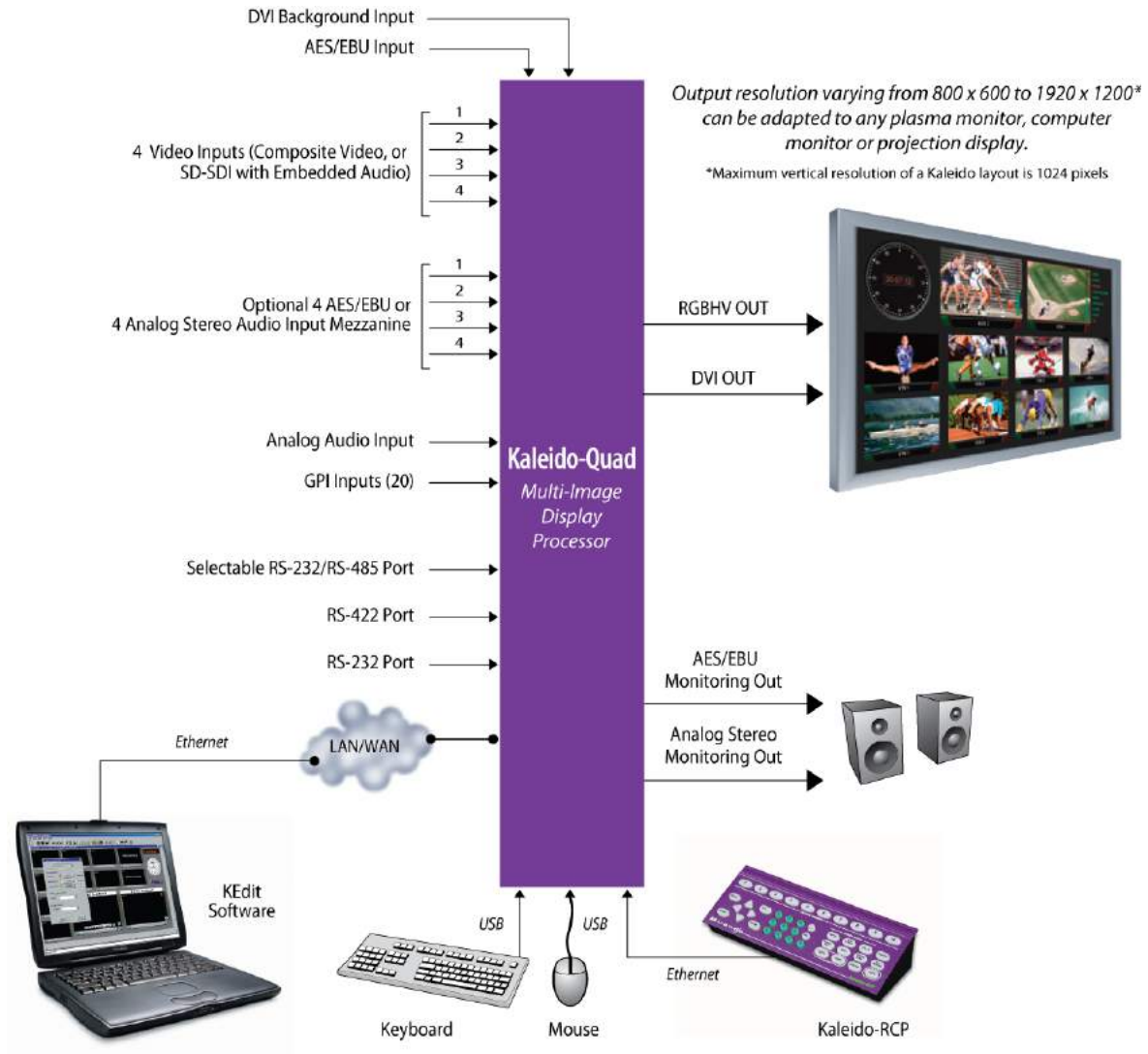

Figure 1.2 Kaleido-Quad-AD configuration



## 2 Installation

### 2.1 Unpacking

Make sure the following items have been shipped with your Kaleido-Alto/Quad. If any of the following items are missing, contact your distributor or Miranda Technologies Inc.

- Kaleido-Alto or Kaleido-Quad unit
- USB mouse
- AC power cord, and retainer clip
- CD with software

### 2.2 Mechanical Installation

Kaleido-Alto/Quad may be installed in a standard 19-inch rack, using the proper screws and washers ( not included). The optional Kaleido-RCP Remote Control Panel may also be installed in a rack using the optional mounting kit (order part #1229-1100-100).

For proper ventilation, make sure the front and side panel air vents are not blocked and the air filter is clean.

### 2.3 Power Connection

Connect the supplied AC power cord to the rear-panel AC receptacle, and secure it with the retainer clip attached to the receptacle. The Kaleido-Alto/Quad includes a universal power supply for 110V and 220V operation.

### 2.4 Signal and Control Connections

All inputs and outputs are located on the rear panel of the Kaleido-Alto/Quad. Signals and connector types are listed and described below. The rear panel labels indicate the appropriate connection point for each signal.

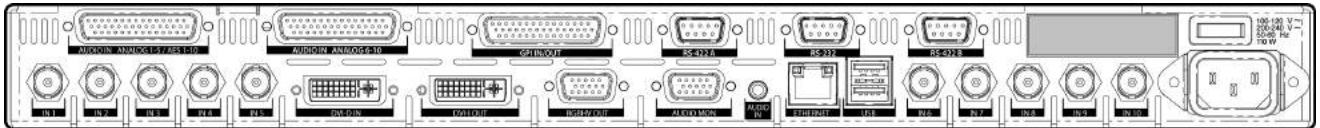

Figure 2.4.1 Kaleido-Alto-AD/A rear panel

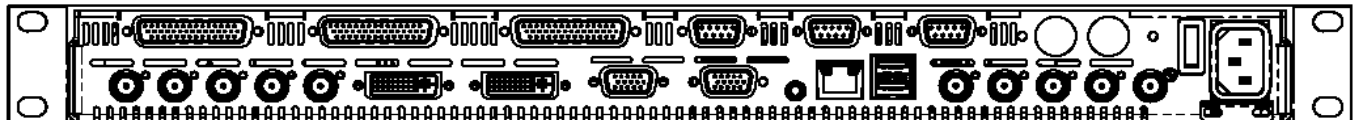

Figure 2.4.2 Kaleido-Alto-HD rear panel

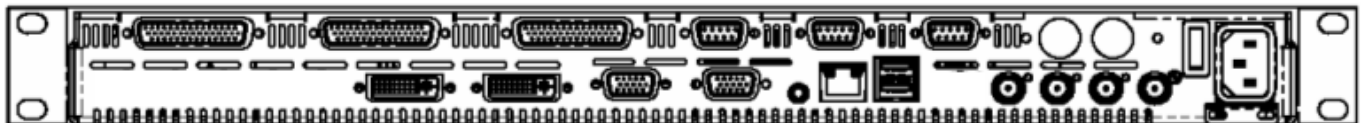

Figure 2.4.3 Kaleido-Quad-HD/AD rear panel

The following chart summarizes the various inputs and outputs appearing on the rear panels of these units, and is followed by a discussion of each of the connections.

Kaleido					Signal connections & communication ports	Connector type
Quad		Alto				
AD	HD	A	AD	HD		
					HD-SDI video inputs	BNC
4	4		10	10	SD-SDI video inputs	BNC
		10			Composite video inputs	BNC
1	1	1	1	1	DVI input	DVI-D
4 or 10	4 or 10	4 or 10	4 or 10	4 or 10	AES/EBU or stereo analog audio input (optional)	DB-44S
1	1	1	1	1	PC audio input	3.5 mm jack
1	1	1	1	1	Component analog (RGBHV) output	DE-15P
1	1	1	1	1	DVI output	DVI-I
1	1	1	1	1	Audio monitoring output	DE-15P
20	20	20	20	20	GPI inputs	DB-44S
10	10	10	10	10	GPI outputs	DB-44S
1	1	1	1	1	Ethernet communication	RJ-45
1	1	1	1	1	RS-422 A port	DE-9
1	1	1	1	1	RS-232 port	DE-9
1	1	1	1	1	RS-422 B port	DE-9
2	2	2	2	2	Mouse and Keyboard	USB type A

**Table 1:** Signal connections

Note that one set of BNC connectors serves all video inputs except the DVI input. The Kaleido-Alto/Quad will auto-detect the type of signal applied, and process it appropriately.

### 2.4.1 HD-SDI Video Inputs

These inputs must conform to the SMPTE 292M standard. The following input formats are supported:

Format	Display Aspect Ratio	Active Pixel	Active Lines	Total Pixels	Total Lines	Pixel Aspect Ratio	Scan Form.	Frame Rate (Hz)	Line Rate (KHz)	Pixel Rate (MHz)	Std. (SMPTE)
1080i 59.94Hz	16:9	1920	1080i	2200	1125	SQR	2:1	29.97	33.72	74.18	274M
1080i 50Hz	16:9	1920	1080i	2376	1250	SQR	2:1	25	31.25	74.25	295M
720p 59.94Hz	16:9	1280	720	1650	750	SQR	1:1	59.94	44.96	74.18	296M
720p 50Hz	16:9	1280	720	1980	750	SQR	1:1	50	37.5	74.25	296M
1080p 29.97Hz	16:9	1920	1080	2200	1125	SQR	1:1	29.97	33.72	74.18	274M
1080p 23.98Hz	16:9	1920	1080	2750	1125	SQR	1:1	23.98	26.97	74.18	274M

Make sure the input cable has a maximum length of 100m (325') (Belden 1694) and that all serial digital video connections are point-to-point. For instance, there must be a point-to-point connection between the IN BNC and the source equipment. If a T-connector is used to connect other equipment, the maximum specified cable length is no longer valid.

### 2.4.2 SD-SDI Video Inputs

The inputs are on BNC connectors and accept 4:2:2 serial digital video signals in either 525 or 625-line format. These inputs must conform to the SMPTE 259M-C standard.

Make sure the input cable has a maximum length of 225m (730' using Belden 1694A), and that all serial digital video connections are point-to-point. For instance, there must be a point-to-point connection between the IN BNC and the source equipment. If a T-connector is used to connect other equipment, the maximum specified cable length is no longer valid.

### 2.4.3 Composite Video Inputs

The inputs are BNC connectors, internally terminated and accept NTSC, PAL, SECAM and monochrome (B&W) video signals. NTSC-M signals must conform to the SMPTE 170M standard and PAL (625/50), PAL-M (525/60) signals must conform to the ITU-R BT.470-6 standard.

### 2.4.4 DVI Input

A DVI signal may be connected to the Kaleido-Alto/Quad to provide a background image behind the monitoring windows. Supported DVI signal resolutions are shown in the table 2 below

**Note:** To use a background image from a source connected through the DVI input, you must make sure that the source computer and your Kaleido's display screen are configured to the same resolution, since no scaling will be applied to the DVI input signal.

Alternatively, a KXI-DVI-Bridge device can be connected upstream to the Kaleido-Alto/Quad in order to provide a scaled background image. See section 2.4.5 "DVI Resolutions Supported with a KXI-DVI-Bridge Connected to the Kaleido's HD-SDI Input" for details.

Kaleido					Resolution (H x V)	Scanning format	Line rate (kHz)	Frame rate (Hz)	
Quad		Alto							
AD	HD	A	AD	HD					
X	X	X	X	X	800 x 600	Progressive	37.7/31.4	59.94	50
X	X	X	X	X	1024 x 768	Progressive	48.4/40.3	59.94	50
X	X	X	X	X	1280 x 768	Progressive	48.1/40.1	59.94	50
X	X	X	X	X	1280 x 1024	Progressive	64/53.3	59.94	50
X	X	X	X	X	1360 x 768	Progressive	47.6/39.8	59.94	50
X	X			X	1600 x 1200	Progressive	74.9/62.5	59.94	50
X	X			X	1920 x 1080	Progressive	69.5/62.5	59.94	50

**Table 2** Supported DVI input signal resolutions

Note that the 1600X1200 and 1920X1080 formats apply only to selected models, and that special consideration is required when using them. See the "Annex – Kaleido Display Resolution" for more information.

### 2.4.5 DVI Resolutions Supported with a KXI-DVI-Bridge Connected to the Kaleido's HD-SDI Input

With a KXI-DVI-Bridge device connected between a computer's DVI output and the HD-SDI input of a Kaleido-Alto-HD or Kaleido-Quad-HD, the following resolutions are supported.

Without dongle:

DVI resolution	HD-SDI output
1024x768 (XGA), 60 Hz	1080i @ 29.97 Hz
1280x1024 (SXGA), 60 Hz	
1366x768 (WXGA), 60 Hz	
1680x1050 (WSXGA+), 60 Hz	

*Suitable for graphic-type images with slow motion.*

With dongle:

DVI resolution	HD-SDI output
1280x720, 50 Hz	720p, 50 Hz
1280x720, 60 Hz	720p, 60 Hz
1920x1080, 50 Hz	1080i, 50 Hz
1920x1080, 60 Hz	1080i, 60 Hz

*Best-quality performance with video-type computer-generated content. No motion artifacts.*

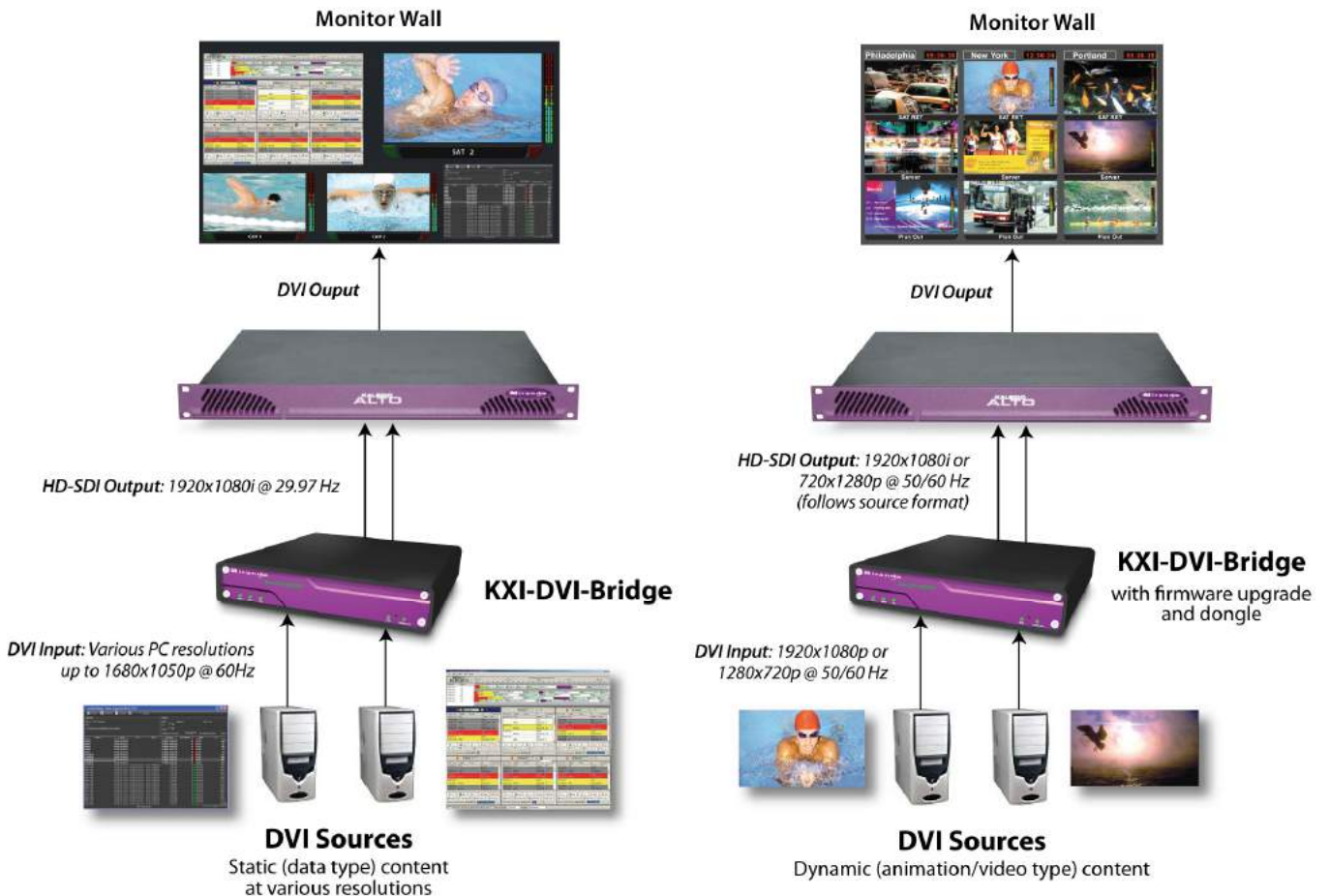

**Note:** The KXI-DVI-Bridge's input can be static content (such as computer-generated text and static graphics) to be scaled and merged against the layout background on the Kaleido. In this case the dongle is generally not required. For the KXI-DVI-Bridge to process dynamic content (such as streaming video or computer-generated animations), the dongle is required. Please refer to your KXI-DVI-Bridge User's Manual for more information.

### 2.4.6 Analog Audio Inputs (Optional Alto-SA Mezzanine with 10 or 4 Inputs)

This option provides inputs for 10 or 4 channels of analog stereo audio. Two DB-44S connectors are available on the Alto-SA mezzanine.

Connect balanced analog stereo audio signals to the audio input connectors. Each connector receives 5 stereo inputs (refer to figure 2.4.4 below for connector pinout). **For the 4-input audio version only inputs IN 1-4 are available.**

To facilitate cabling of the audio inputs, a terminal block adapter is available separately (Alto-TBA-AG). A Lexan plate is provided to identify the terminal assignment for the input connectors. See figure 2.4.6 for plate installation on the Alto-TBA-AG terminal block adapter.

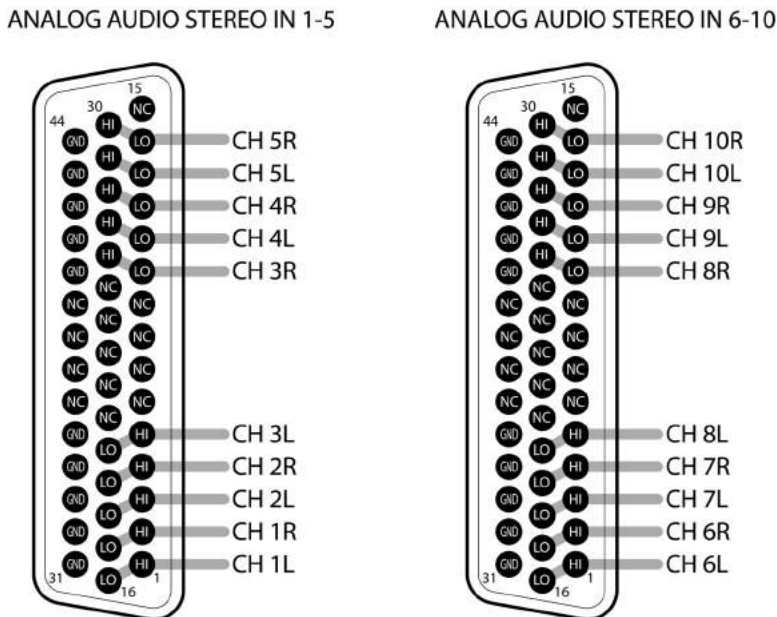

Figure 2.4.4 Analog audio connector pinout

### 2.4.7 Digital Audio Input (Optional Alto-AES Mezzanine)

This option provides inputs for 10 or 4 channels of AES/EBU digital audio. A single DB-44S connector is available on the Alto-AES mezzanine.

Connect AES balanced audio signals to the audio input connector. Signal must conform to AES3-1992/ANSI S4.40-1992 standard. The DB-44 connector receives 10 inputs (refer to figure 2.4.5 below for connector pinout). **For the 4-input audio version only inputs IN 1-4 are available.**

To facilitate cabling of the audio inputs, a terminal block adapter is available separately (Alto-TBA-AG). A Lexan plate is provided to identify the terminals assignment for the input connectors. See figure 2.4.6 for Lexan plate installation on the Alto-TBA-AG terminal block adapter.



### 2.4.11 Audio Monitoring Output

A DE-15P connector is provided to monitor one stereo audio channel, in both balanced AES3 and analog formats. Refer to figure 2.4.8 for connector pinout.

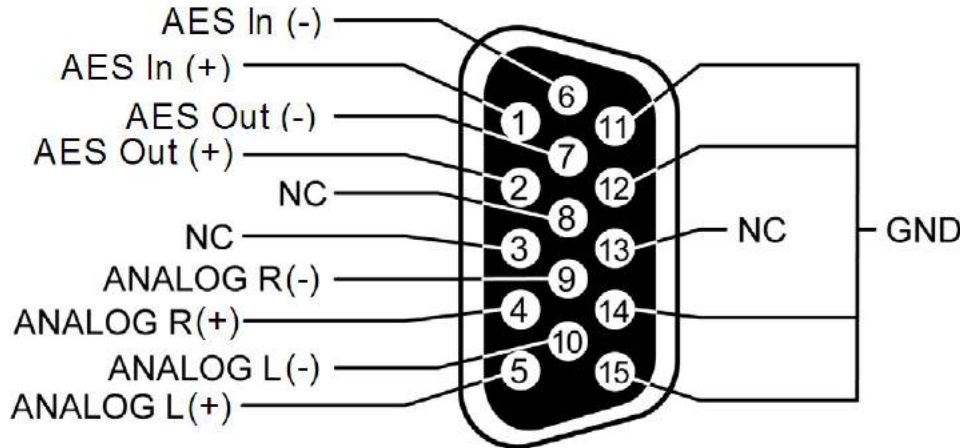

Figure 2.4.8 Audio monitoring connector pinout

### 2.4.12 GPI Inputs /Outputs

The GPI input connector provides interfaces and processing to support 20 contact closure tally inputs and provisions to support 10 outputs using DB-44S connectors. The connector pinout and circuit schematics are shown in figure 2.4.9 and 2.4.10 below.

To facilitate cabling of the GPI inputs and outputs, a terminal block adapter is available separately (Alto-TBA-AG). A double-sided Lexan plate is provided to identify the terminals assignment for both input and output connectors. Place the Lexan plate as indicated in figure below, and install cables and plug the adapter into the connector.

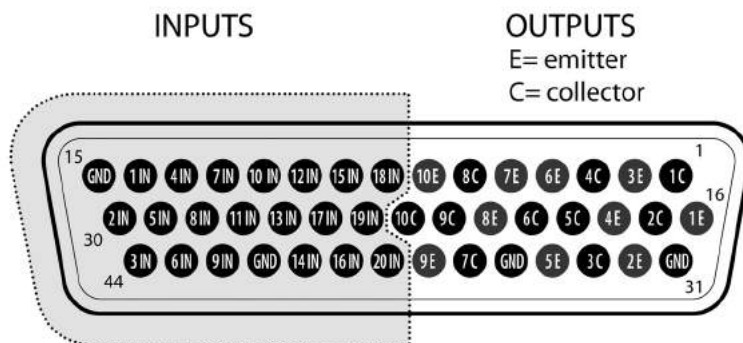

Figure 2.4.9 GPI Connector pinout

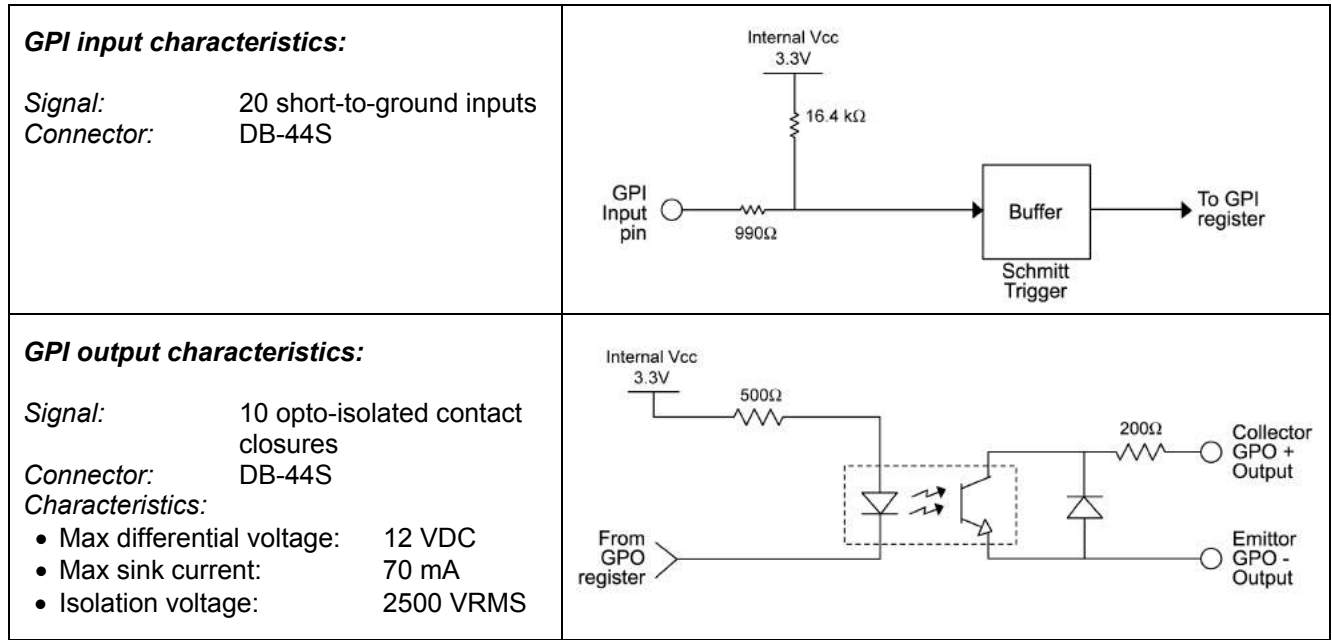

Figure 2.4.10 GPI I/O characteristics

**RS-422 A**

DE-9S connector for connecting remote control devices such as routers or the Kaleido-RCP (12V is supplied through pin 5 to the Kaleido-RCP).

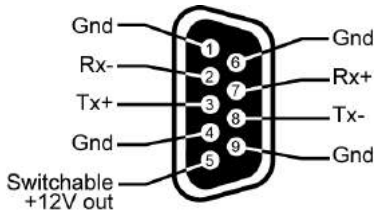

Figure 2.4.11 RS-422 A Connector pinout

**RS-232**

DE-9P connector to connect to router status information sources for tracking UMDs or inputting time code using a device such as Miranda’s “Little Red”.

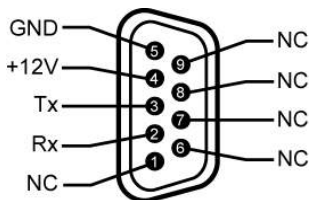
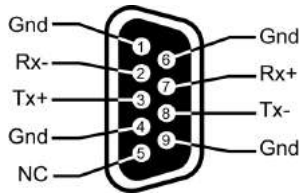

Figure 2.4.12 RS-232 Connector pinout



**RS-422 B**

DE-9S connector for connecting remote control devices such as routers.



*Figure 2.4.13 RS-422 B Connector pinout*

**2.4.13 Ethernet**

An RJ-45 connector for 10/100Base-T Ethernet interface connection to LAN/WAN networks using TCP-IP.

**2.4.14 USB**

Dual USB 1.0 ports used to connect a mouse (supplied) and keyboard to allow the user to operate the Kaleido-Alto/Quad.

**Note:** Multi-function keyboards (i.e. with built-in USB ports, volume controls and other special buttons) are not supported, so make sure to use a simple, basic USB keyboard.

**2.5 Dual power supplies (Optional)**

The Kaleido-Alto-HD and the Kaleido-Quad-HD/SD can be configured with dual power supplies. The figure shows the location of the power supplies in the base configuration (single power supply) and the option dual-supply configuration.

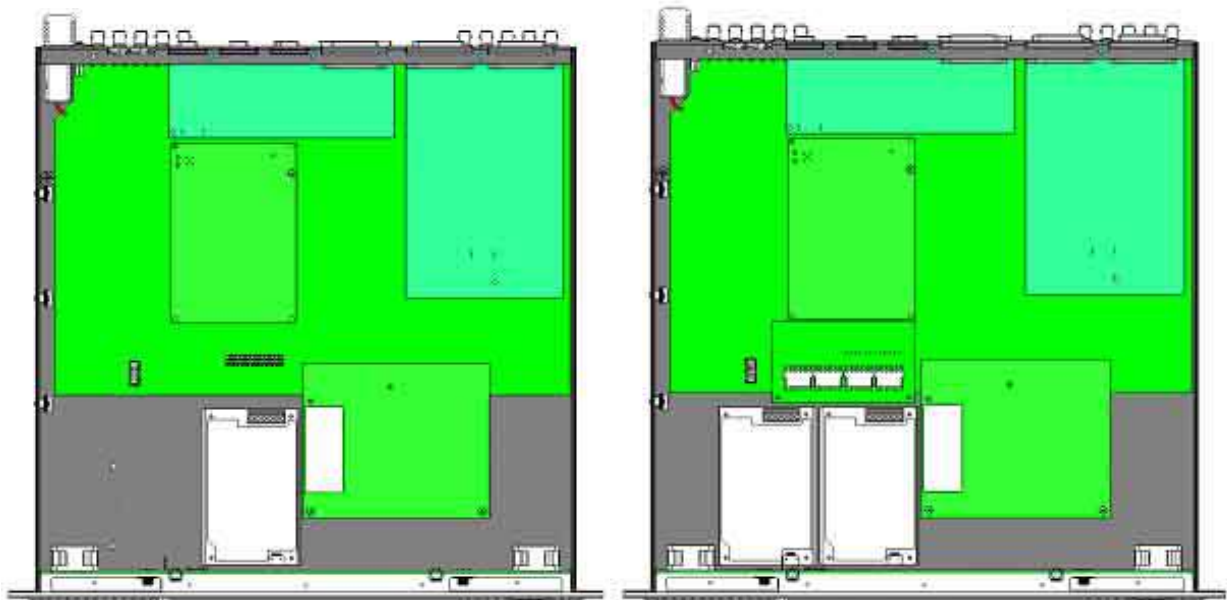

The user can associate a software Alarm with these power supplies in order to monitor their status from a remote location via iControl.

## 2.6 Multiple Kaleido-Alto/Quad Installations

### 2.6.1 Ethernet Connection for use with KEdit

KEdit software is used to create layouts for the Kaleido-Alto/Quad. Each Kaleido-Alto/Quad can have layouts created specifically for its application requirements. These layouts are created on a PC running KEdit software (described in its own manual) and uploaded to the Kaleido-Alto/Quad via Ethernet, each Kaleido-Alto/Quad having its own IP address.

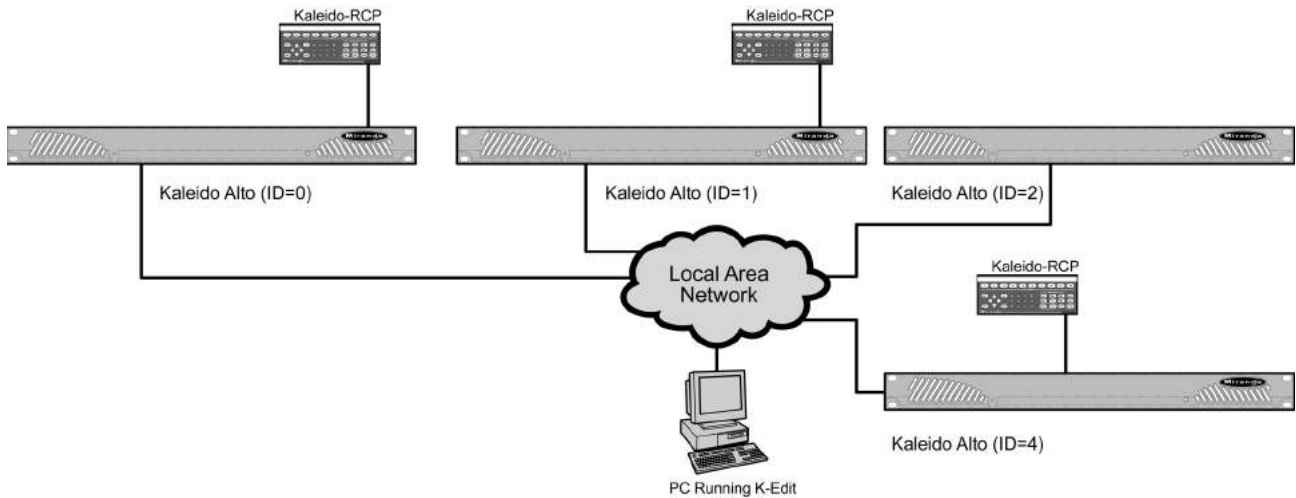

Figure 2.5.1 Kaleido-Alto/Quads connected to an Ethernet network

### 2.6.2 Controlling Multiple Kaleido-Alto/Quad units from a Kaleido-RCP

Using the RS-422 A communication port allows up to 99 daisy-chained Kaleido-Alto/Quad frames to be controlled using only one Kaleido-RCP, through the use of a multidrop cable. Figure 2.5.2 illustrates cabling between the Kaleido-Alto/Quads and the Kaleido-RCP. Other products in the Kaleido family may be included, as shown in the figure.

For this to work, the Kaleido-RCP must be able to send commands to a specific Kaleido-Alto/Quad in the daisy-chain. This is accomplished by assigning an identification code to each of the Kaleido-Alto/Quad frames.

By default, Kaleido-RCP will send instructions using RS-422 protocol to ID 1. This means that a system comprised of only one Kaleido-Alto frame will work out of the box as each frame's default ID is also set to 1. However, for applications where more than one Kaleido-Alto/Quad frame is used, you will need to assign a unique ID number to each of them. Consult the Kaleido-Alto/Quad/Quad-Dual User's Manual for details.

As indicated in the figure below, a 120  $\Omega$  termination resistor must be installed on the cable connector on the last Kaleido-Alto/Quad frame in the daisy-chain. In a point-to-point connection, it must be installed on the receiver; for a more-than-one Kaleido-Alto/Quad frame connection (called a "multidrop connection"), it must be installed on receiver **and** driver. For more details, consult Miranda Application Note #229-99T00-101.

## RS-422 Multi-drop Cable Example

**Notes:**

- 1: For pins 2/7 and 3/8, using Belden 8162 or similar is recommended, 24AWG. 2 Twisted Pairs individually shielded, both GND and the Overall foil connected to pin 1
- 2: For PINS 4 and 5, wires should be 20AWG.
- 3: As illustrated, it is strongly recommended to get 12V required for the RCP from an external DC supply or AC/DC adaptor. It shall deliver 3W or more (250mA or more). The distance between the supply and the RCP should be the shortest possible.
- 4: As illustrated, the Tango has Tx and Rx signals located at different pins than other Kaleido products.

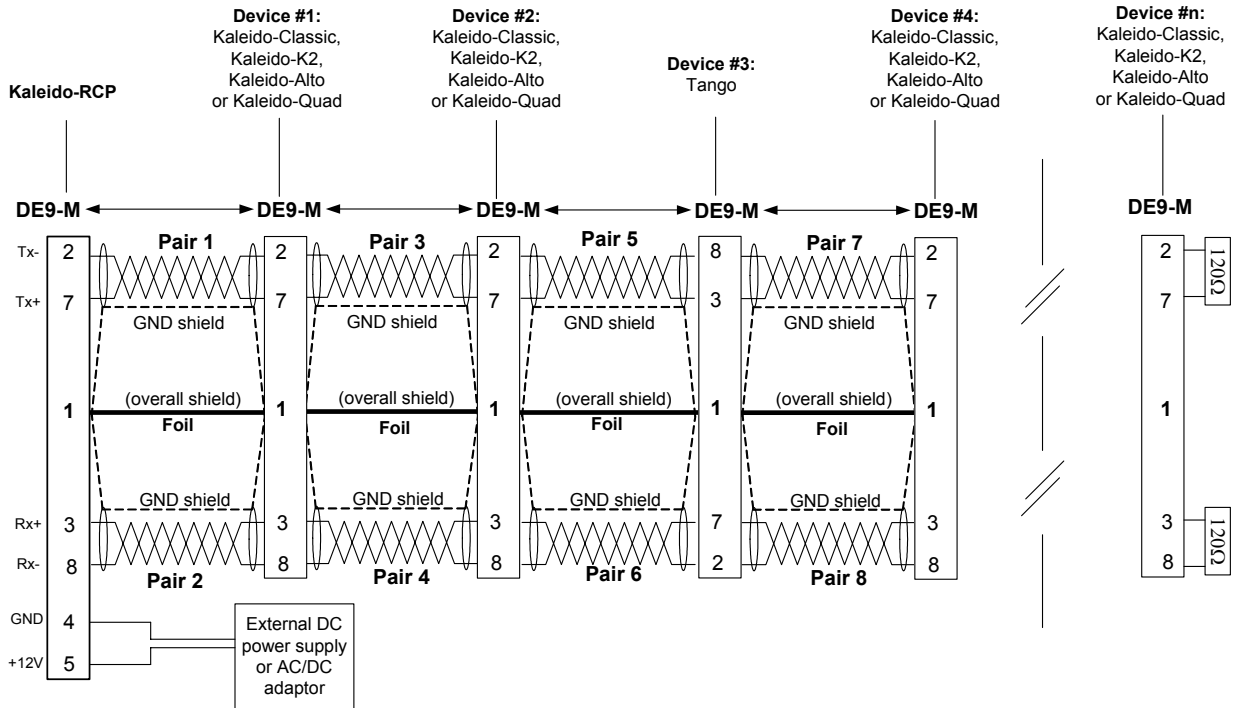

Figure 2.5.2 Kaleido Alto/Kaleido-RCP interconnection for cascading multiple frames

### 3 Operation

The Kaleido-Alto has no local controls beyond the power switch. Operational concerns are outlined here, but for detailed operating instructions, see the Kaleido-Alto/Quad/Quad-Dual User's Manual. Periodically, new software versions may be uploaded using "live update" through the Ethernet connection.

#### 3.1 Powering Up

The power switch is located on the rear panel of the Kaleido-Alto/Quad, just above the power cord. Plug the cord into an appropriate AC power supply, and set the switch to ON ( I ). **If you have just switched the unit OFF ( 0 ), always wait a few seconds before turning it ON again to ensure proper startup procedure.**

#### 3.2 Front Panel Status LED

There is a system status LED mounted on the front panel of the Kaleido-Alto/Quad. This LED gives operational status when powering up the unit, and signals any malfunction of the unit. Note that this LED does not report on the status of the inputs connected at the back.



*Figure 3.1 Front panel status LED (same location on Alto and Quad)*

At startup, the LED will briefly light up red, then flashing yellow. After 10 to 15 seconds the LED lights up green to indicate normal system operation. Other states may be:

- Yellow** (continuous): System boot-up problem or live update not completed correctly
- Red** (continuous): System failure

#### 3.3 Startup and Preparation

The Kaleido-Alto is shipped with the current version of the software installed, and configured to auto-start when the system is powered on. Upon initial startup, the system will present the default monitoring window at its output. Upon subsequent start-ups, the system will present the last monitoring window that was present before shut-down. See the Kaleido-Alto/Quad/Quad-Dual User's Manual for detailed instructions on how to operate the software.

#### 3.4 Software Installation

In case of recovery from a system failure, or when a software update is available, it may be necessary to install the Kaleido-Alto/Quad/Quad-Dual software or the KEdit layout editor. All the necessary software is delivered on a CD included in the product package, or downloaded from Miranda's web site. As the Kaleido-Alto/Quad unit does not have a CD drive, it is necessary to install the software from a remote computer through a network connection. Installation of the software is detailed in a *ReadMe* file included with the update.

## 4 Technical Specifications

### 4.1 Inputs

INPUTS	Kaleido Model	ALTO			QUAD	
		HD	AD	A	HD	AD
<b>Digital Video Input (HD-SDI)</b>		<b>10</b>	<b>NA</b>	<b>NA</b>	<b>4</b>	<b>NA</b>
Signal	SMPTE 292M					
Cable Length	100m (325') (Belden 1694)					
Return Loss	15dB up to 1.5Gbps					
Impedance	75Ω					
Connector	BNC					
<b>Digital Video Input (SD-SDI)</b>		<b>10</b>	<b>10</b>	<b>NA</b>	<b>4</b>	<b>4</b>
Signal	4:2:2 SMPTE 272M, 259M-C					
Cable Length	225 m (Belden 1694A)					
Return Loss	15dB up to 270 MHz					
Impedance	75Ω					
Connector	BNC					
<b>Composite Video Input</b>		<b>10</b>	<b>10</b>	<b>10</b>	<b>4</b>	<b>4</b>
Signal	NTSC SMPTE 170M, PAL, PAL-M, SECAM, B&W					
Return Loss	35dB up to 5.75MHz					
Quantization	8 bits					
Impedance	75Ω					
Connector	BNC					
<b>DVI-D Input (High res)</b>		<b>1</b>	<b>NA</b>	<b>NA</b>	<b>1</b>	<b>1</b>
Signal	Digital DVI					
Cable Length	3.6 m (12') with Altinex CB4012DV					
Resolution	800x600 to 1920X1080 w/56LB at 50/59.94 Hz (see <a href="#">table 2</a> on page 7 for details)					
Connector	DVI					
<b>DVI-D Input (Limited res)</b>		<b>NA</b>	<b>1</b>	<b>1</b>	<b>NA</b>	<b>NA</b>
Signal	Digital DVI					
Cable Length	3.6 m (12') with Altinex CB4012DV					
Resolution	800x600 to 1280X1024 at 50/59.94 Hz (see <a href="#">table 2</a> on page 7 for details)					
Connector	DVI					
<b>HD Embedded Audio Input</b>		<b>10</b>	<b>NA</b>	<b>NA</b>	<b>4</b>	<b>NA</b>
Signal	SMPTE 292M					
Bit Resolution	20-24 bits					
Sampling Rate	48 kHz synchronous					
<b>SD Embedded Audio Input</b>		<b>10</b>	<b>10</b>	<b>NA</b>	<b>4</b>	<b>4</b>
Signal	SMPTE-272M					
Bit Resolution	20 bits					
Sampling Rate	48 kHz synchronous					

.....continued

INPUTS (continued)	Kaleido Model	ALTO			QUAD	
		HD	AD	A	HD	AD
<b>PC Audio</b>		<b>1</b>	<b>1</b>	<b>1</b>	<b>1</b>	<b>1</b>
Signal	Analog Stereo, source level adjustable					
Impedance	16kΩ					
Max. level	2V peak to peak					
Sampling Rate	48 kHz free run					
Bit Resolution	20 bits					
Connector	Stereo audio jack 3.5 mm					

## 4.2 Outputs

OUTPUTS	Kaleido Model	ALTO			QUAD	
		HD	AD	A	HD	AD
<b>RGBHV Progressive Output (High Res)</b>		<b>1</b>	<b>NA</b>	<b>NA</b>	<b>1</b>	<b>1</b>
Resolution:	800x600 to 1920X1080 w/56LB at 50/59.94 Hz (see <a href="#">table 2</a> on page 7 for details)					
H Frequency	From 31.4 kHz to 74.9 kHz					
V Frequency	50/59.94 Hz					
Level	0.7 or 1.0 Vp-p (selectable software)					
Cable Length	Short, Medium, Long					
Connector	DE-15S					
<b>RGBHV Progressive Output (Limited res)</b>		<b>NA</b>	<b>1</b>	<b>1</b>	<b>NA</b>	<b>NA</b>
Resolution	800x600 to 1280X1024 at 50/59.94 Hz (see <a href="#">table 2</a> on page 7 for details)					
H Frequency	From 31.4 kHz to 74.9 kHz					
V Frequency	50/59.94 Hz					
Level	0.7 or 1.0 Vp-p (selectable software)					
Cable Length	Short, Medium, Long					
Connector	DE-15S					
<b>DVI-I Output (high resolution)</b>		<b>1</b>	<b>NA</b>	<b>NA</b>	<b>1</b>	<b>1</b>
Signal	Digital DVI					
Cable Length	3.6 m (12') with Altinex CB4012DV					
Resolution	800x600 to 1920X1080 w/56LB at 50/59.94 Hz (see <a href="#">table 2</a> on page 7 for details)					
Connector	DVI					
<b>DVI-I Output (limited resolution)</b>		<b>1</b>	<b>NA</b>	<b>NA</b>	<b>1</b>	<b>1</b>
Signal	Digital DVI					
Cable Length	3.6 m (12') with Altinex CB4012DV					
Resolution	800x600 to 1280X1024 at 50/59.94 Hz (see <a href="#">table 2</a> on page 7 for details)					
Connector	DVI					

.....continued

OUTPUTS (continued)	Kaleido Model	ALTO			QUAD	
		HD	AD	A	HD	AD
<b>AES Audio Output</b>		<b>1</b>	<b>1</b>	<b>1</b>	<b>1</b>	<b>1</b>
Signal	AES3					
Quantization	20 bits					
Impedance	110Ω					
Attenuation	Minimum level 0 dBFs (step 6 dBFs)					
Sampling Rate	48 KHz					
Connector	DE-15S					
<b>Analog Stereo Audio Output</b>		<b>1</b>	<b>1</b>	<b>1</b>	<b>1</b>	<b>1</b>
Signal	1 stereo balanced output					
Quantization	20 bits (minimum)					
Impedance	<50Ω					
Level	+24 dBu, adjustable level (step 6 dBu)					
SNR	98dB (A weighting) up to 20-22kHz					
THD+N	80dB @ 1kHz					
Frequency response	+/- 0.3dB					
Connector	DE-15S					

### 4.3 Control

CONTROL	All models
<b>GPI Inputs</b>	
Contact closure	GND
Total cable length	200'
Minimum pulse duration	100 ms
Connector	DB-44S
<b>GPI Outputs</b>	
Max. voltage	12 VDC differential voltage
Cable length	100 ms
Connector	DB-44S
<b>RS-232</b>	
Signal	RS-232 (EIA/TIA-232)
Baud rate	9600 BPS, according to application
Connector	DE-9P
<b>RS-422 A</b>	
Signal	RS-422 (SMPTE 207M, EBU-3245) (a 12V power supply on pin 5 is provided for the Kaleido-RCP)
Data rate	38400 BPS, according to application
Connector	DE-9S

.....continued

<b>CONTROL</b> (continued)		<b>All Models</b>
<b>RS-422 B</b>		
Signal	RS-422 (SMPTE 207M, EBU-3245)	
Data rate	38400 BPS, according to application	
Connector	DE-9S	
<b>Ethernet</b>		
Signal	10Base-T, 100Base-T (IEEE 802.3)	
Connector	RJ-45	
<b>USB</b>		
Signal	USB ver. 1.0	
Connector	USB double type receptacle A	

#### 4.4 Processing Performance

<b>PROCESSING PERFORMANCE</b>	<b>All models</b>
Signal path	8 bits
Quantization	24 bits on RGBVH output
Graphic	18 bits on RGB
Maximum video processing delay to DVI output	60 Hz: less than 34 ms 50 Hz: less than 44 ms

#### 4.5 Frame

<b>FRAME</b>	
<b>Kaleido-Alto-AD/A</b>	
Voltage	100-240 VAC
Power	90 W
Dimensions	1RU (19-inch rack) X 19.25 in (490 mm) deep
Weight	8.1lbs (3.7 kg)
Operating temperature	0-40° C
<b>Kaleido-Alto-HD, Kaleido-Quad-HD/AD</b>	
Voltage	100-240 VAC
Power	110 W ( <b>Kaleido-Alto-HD</b> )
Power	50 W ( <b>Kaleido-Quad-HD/AD</b> )
Dimensions	1RU (19-inch rack) X 19.25 in (490mm) deep
Weight	10lbs (4.5 kg)
Operating temperature	0-40° C DB-44S



## Annex – Kaleido Display Resolution

The Kaleido-Alto/Quad displays all the elements of its layout in a frame whose maximum vertical resolution is 1024 pixels. However, the RGBHV output from all versions of the Kaleido-Alto and the Kaleido-Quad can drive displays with greater vertical resolution, provided they are equipped with an appropriate hardware version (see the chart below). In particular, displays operating at 1920x1080 and 1600x1200 can be used with these Kaleido models.

### 1600 x 1200 resolution:

To drive a 1600x1200 display, the Kaleido layout must be created at 1600x1024 pixels. In KEdit, you must generate a 25 x 16 display aspect ratio. When this layout is shown on the display, 88 lines on top and bottom will be displayed in black.

### 1920 x 1080 resolution:

To drive a 1920x1080 display, the Kaleido layout must be created at 1920x1024 pixels. In KEdit, you must generate a 15 x 8 display aspect ratio. When this layout is shown on the display, 28 lines on top and bottom will be displayed in black.



**Figure A1** Kaleido-Alto output on a 1920x1080 display showing black bars at the top and bottom

A feature of Kaleido-Alto/Quad is the ability to replace the internally-generated background in the layout with images from an external source, via the DVI input. In this case, it is appropriate to select a DVI background source to match the display in use, i.e. 1600x1200 or 1920x1080. The background will occupy the entire display screen, and the Kaleido-generated elements will be keyed into the vertically-centered 1024-line portion of the screen, with no visible indication of any boundaries within the image (see figure A2).

Three sets of alternative “color keys” can be used by the background application. For example, in the case of integration with iControl Web, the background uses (255 blue, 255 green and 0 red).



**Figure A2** Kaleido-Quad output on a 1920x1080 display showing the DVI background occupying the entire display with the Kaleido layout elements keyed in.

### Higher-resolution output support

Here is a chart of Kaleido-Alto/Quad models and hardware revisions that will support output at 1920x1080 and 1600x1200 resolution:

Kaleido Models	Hardware revision: 200 = v200 base version 200* = v200 enhanced version	Resolution higher than 1024 lines (i.e. 1920 x 1080 and 1600 x 1200) displayed in letter box format)
Kaleido-Alto-A	100 - 200	Not Supported
	200*	Supported
Kaleido-Alto-D	100 - 200	Not Supported
	200*	Supported
Kaleido-Alto-AD	100 - 200	Not Supported
	200*	Supported
Kaleido-Alto-A2	300 and higher	Supported
Kaleido-Alto-AD2	300 and higher	Supported
Kaleido-Alto-HD	300 and higher	Supported
Kaleido-Quad-HD	300 and higher	Supported
Kaleido-Quad-AD	300 and higher	Supported

## Contact Us!

### Miranda Technical Support

---

For technical assistance, please contact the Miranda Technical Support centre nearest you:

#### **Americas**

Office hours: 9:00 a.m. – 9:00 p.m. (EST)  
Telephone: +1-800-224-7882  
Fax: +1-514-335-1614  
E-mail: [techsupp@miranda.com](mailto:techsupp@miranda.com)

#### **Asia**

Office hours: 9:00 a.m. – 5:00 p.m. (GMT+8)  
Telephone: +852-2539-6987  
Fax: +852-2539-0804  
E-mail: [asiatech@miranda.com](mailto:asiatech@miranda.com)

#### **Europe, Middle East, Africa, UK**

Office hours: 9:00 a.m. – 6:00 p.m. (GMT)  
Telephone: +44 (0) 1491 820222  
Fax: +44 (0) 1491 820002  
E-mail: [eurotech@miranda.com](mailto:eurotech@miranda.com)

#### **China**

Telephone: +86-10-5873-1814  
E-mail: [asiatech@miranda.com](mailto:asiatech@miranda.com)

#### **France**

Office hours: 9:00 a.m. – 5:00 p.m. (GMT+1)  
Telephone: +33 1 55 86 87 88  
Fax: +33 1 55 86 00 29  
E-mail: [eurotech@miranda.com](mailto:eurotech@miranda.com)

### Corporate Head Office

---

#### **Miranda Technologies Inc.**

3499 Douglas-B.-Floreani, St-Laurent, Quebec, Canada H4S 1Y6  
Telephone: 514-333-1772  
Fax: 514-333-9828  
Web: [www.miranda.com](http://www.miranda.com)