

SOUND DEVICES



CL-12

Linear Fader Controller for the 6-Series

User Guide

Legal Notices

Product specifications and features are subject to change without prior notification.

Copyright © 2018 Sound Devices, LLC. All rights reserved.

This product is subject to the terms and conditions of a software license agreement provided with the product, and may be used in accordance with the license agreement.

This document is protected under copyright law. An authorized licensee of this product may reproduce this publication for the licensee's own personal use. This document may not be reproduced or distributed, in whole or in part, for commercial purposes, such as selling copies or providing educational services or support.

This document is supplied as a technical guide. Special care has been taken in preparing the information for publication; however, since product specifications are subject to change, this document might contain omissions and technical or typographical inaccuracies. Sound Devices, LLC does not accept responsibility for any losses due to the user of this guide.

Trademarks

The "wave" logo and USBPre are registered trademarks; FileSafe, PowerSafe, SuperSlot, MixAssist, QuickBoot, and Wave Agent are trademarks of Sound Devices, LLC. Mac and OS X are trademarks of Apple Inc., registered in the U.S. and other countries. Windows and Microsoft Excel are registered trademarks of Microsoft Corporation in the U.S. and other countries. All other trademarks herein are the property of their respective owners.

FCC Notice

This device complies with part 15 of the FCC Rules. Operation is subject to the following two conditions: (1) This device may not cause harmful interference, and (2) This device must accept any interference received, including interference that may cause undesired operation.

FCC Part 15.19(a)(3)

Manual Conventions

Symbol	Description
>	This symbol is used to show the order in which you select menu commands and sub-options, such as: Main Menu > Audio indicates you press the Menu button for the Main Menu, then scroll to and select Audio by pushing the Control Knob.
+	A plus sign is used to show button or keystroke combinations. For instance, Ctrl+V means to hold the Control key down and press the V key simultaneously. This also applies to other controls, such as switches and encoders. For instance, MIC+HP turn means to slide and hold the MIC/TONE switch left while turning the Headphone (HP) encoder. METERS+SELECT means to hold the METERS button down as you press the SELECT encoder.
ⓘ	A note provides recommendations and important related information. The text for notes also appears in a different color and italicized.
⚠	A cautionary warning about a specific action that could cause harm to you, the device, or cause you to lose data. Follow the guidelines in this document or on the unit itself when handling electrical equipment. The text for cautionary notes also appears in a different color, bold and italicized.

CL-12 User Guide • Rev 4-B • Aug 13, 2018

This document is distributed by Sound Devices, LLC in online electronic (PDF) format only. E-published in the USA.

www.sounddevices.com

support@sounddevices.com

Sound Devices, LLC

E7556 Road 23 and 33

Reedsburg, Wisconsin 53959 USA

Direct: +1 (608) 524-0625

Toll Free: (800) 505-0625

Fax: +1 (608) 524-0655

Revision History

This table provides the revision history of this guide.

Rev#	Date	Firmware Version	Description
1-A	Oct 2015	v1.00	Initial Official Publication
2-A	Feb 2016	v2.11	Updated with information regarding integration with the rest of the 6-Series of Mixers/Recorders <ul style="list-style-type: none">• New "Feature Comparison Chart" on page 41• Updated: "CL-12 Sub-menu" on page 42• New section: "Adjusting Trim Levels (664 only)" on page 45• New section: "Adjusting Trim Levels (633 only)" on page 45• Updated: "Adjusting Output or Track Levels" on page 46• Updated: "Using High-pass Filters" on page 53• Updated table in: "Configuring User Programmable Buttons" on page 54
2-B	Feb 2016	v2.11	Minor alteration to the Feature Comparison Chart.
3-A	June 2016	v3.10	Updated with new information on disabling Output controls. <ul style="list-style-type: none">• New section: "Disabling Output Controls" on page 47
4-A	July 2018	v4.53	<ul style="list-style-type: none">• Added Install & Replacing Panel sections from discontinued Quick Start Guide.
4-B	Aug 2018	v4.53	<ul style="list-style-type: none">• Minor edits to fix hyperlinks



Table of Contents

CL-12 Linear Fader Controller

Connecting CL-12 to 6-Series Mixer	7	Disabling Output Controls	22
Overview of Panels	9	Arming L, R, X1, X2 Tracks	22
Top: EQ & OUTPUTS Sections	11	Using the 3-Band Equalizer (688 only)	23
Left: Channel Strip Section	12	Accessing the EQ Submenu	24
Right: Buttons and HP Encoder	14	Bypassing EQ	26
Altered Functionality	16	Setting the Q-Factor	26
Feature Comparison Chart	16	Setting LF and HF Frequency Defaults	27
CL-12 Sub-menu	17	Setting LF and HF Filter Types	27
Selecting One or More Input Channels	18	Setting EQ Routing	28
Activating PFL of an Input	19	Using High-pass Filters	28
Setting SEL to follow PFL	19	Naming Tracks	29
Trim Level Adjustment on 6-Series	19	Configuring User Programmable Buttons	30
Adjusting Trim Levels (688 only)	20	Adjusting CL-12's LED Brightness	31
Adjusting Trim Levels (664 only)	20	Replacing Side Panels	31
Adjusting Trim Levels (633 only)	20	Specifications	32
Routing Input Channels	21		
Adjusting Output or Track Levels	21		
Configuring Output Meters (688 only)	22		

CL-12 Linear Fader Controller

The CL-12 linear fader controller, which comes in two models, is an optional accessory that significantly expands the mixing capability of the 6-Series mixer/recorder line.

The standard CL-12 adds 12 linear faders, numerous fast-access buttons, and enhanced, daylight viewable LED metering.

The CL-12 Alaia™ has the same impressive feature-set the standard CL-12 offers, but also includes pro-quality, smooth gliding Penny & Giles faders as well as custom hardwood side panels in two finishes.

The CL-12 Alaia™ also ships with an Aluminum Endcap Kit. For more details, see [Replacing Side Panels](#).

Topics in this section include:

- ▶ Connecting CL-12 to 6-Series Mixer
- ▶ Overview of Panels
- ▶ Altered Functionality
- ▶ Selecting One or More Input Channels
- ▶ Activating PFL of an Input
- ▶ Trim Level Adjustment on 6-Series
- ▶ Routing Input Channels
- ▶ Adjusting Output or Track Levels
- ▶ Disabling Output Controls
- ▶ Arming L, R, X1, X2 Tracks
- ▶ Using the 3-Band Equalizer (688 only)
- ▶ Using High-pass Filters
- ▶ Naming Tracks
- ▶ Configuring User Programmable Buttons
- ▶ Adjusting CL-12's LED Brightness
- ▶ Replacing Side Panels
- ▶ Specifications

Connecting CL-12 to 6-Series Mixer

It connects via a USB cable, which provides both power and control of the CL-12, plus a ¼-inch headphone cable to provide both a ground connection to the chassis as well as monitoring from the CL-12. Additional power via a micro USB cable is required when connecting the CL-12 to a 664 or 633. This additional power source is optional when attaching the CL-12 with a 688, but recommended when power-hungry USB peripherals are used, such as higher-power USB keyboards or lights.

⚠ CAUTION: *To avoid sudden level changes, it is recommended that all rotary faders on the mixer and linear faders on the CL-12 be set to -infinity before connecting or disconnecting the the CL-12 accessory. When the CL-12 is connected, fader levels are determined by the linear faders; when disconnected, levels are set by the mixer's rotary faders.*

To connect the CL-12 to the mixer:

1. Connect one end of a micro USB power cord to the DC Boost Input on the CL-12's back panel and the other end to an external power source.

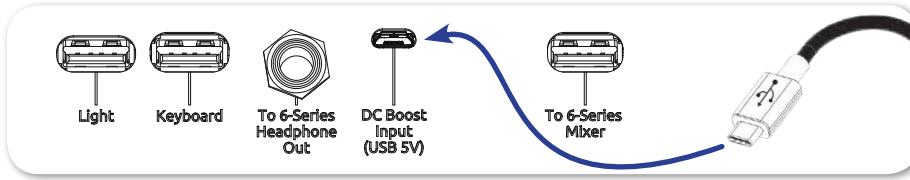

When extra power is connected via DC Boost Input, illumination of the LEDs and backlit buttons on the CL-12 will be brighter.

- Using the TRS headphone cable provided with the CL-12, connect the mixer's 1/4-inch unbalanced stereo headphone output to the CL-12's 1/4-inch headphone input on its back panel.

As well as providing a solid low-noise path for the headphone signal, the supplied 1/4-inch TRS cable also adds a low-resistance ground connection to the CL-12 chassis. This additional connection gives extra robustness to the mixer/CL-12 in the presence of static shocks to the CL-12 chassis.

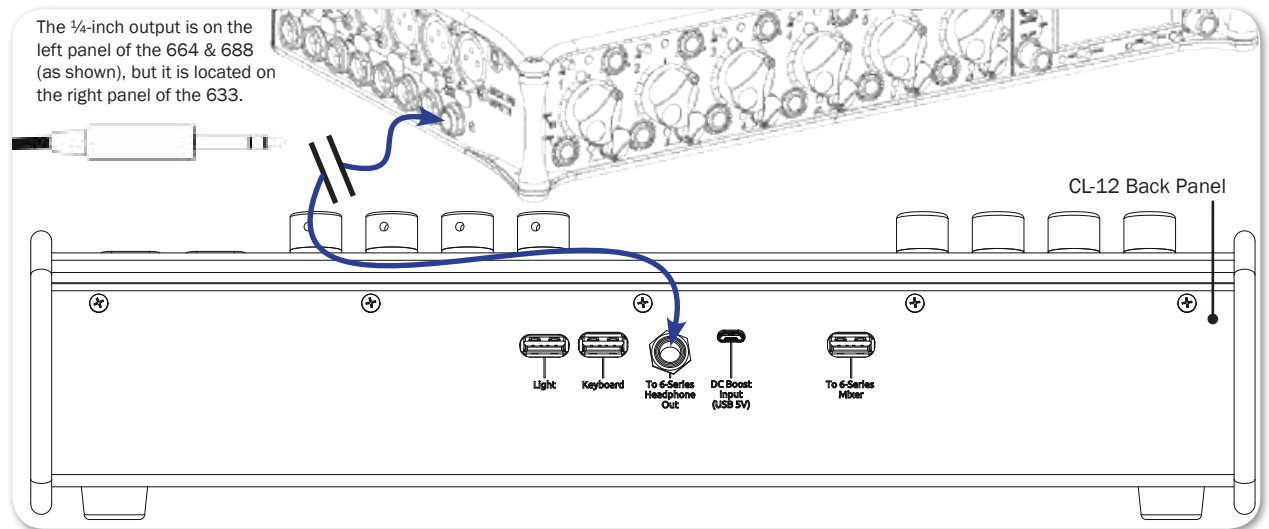

- Using a standard USB A-to-B cable, insert the B connector into the mixer's USB port on the right side panel.



- Insert the A connector into the USB port, labeled To 6-Series Mixer, on the back panel of the CL-12.

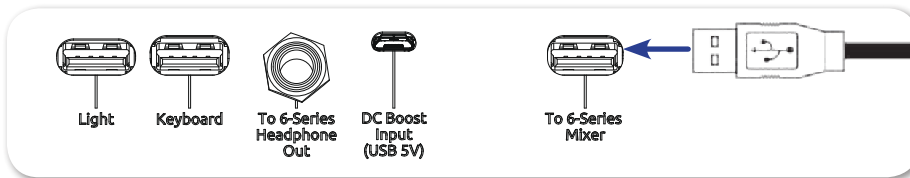

① *The other USB ports on the back of the CL-12, and labeled respectively as Light and Keyboard, may be used to attach an external USB light, and a keyboard for easier metadata entry.*

5. Plug headphones into either HP port— $\frac{1}{4}$ -inch or $\frac{1}{8}$ -inch (3.5 mm)—on the front panel of the CL-12.

Overview of Panels

The front and back panels of the CL-12 provide a number of connection ports for a variety of purposes. The front panel has two headphone outputs, a $\frac{1}{4}$ -inch and a 3.5 mm TRS jack.

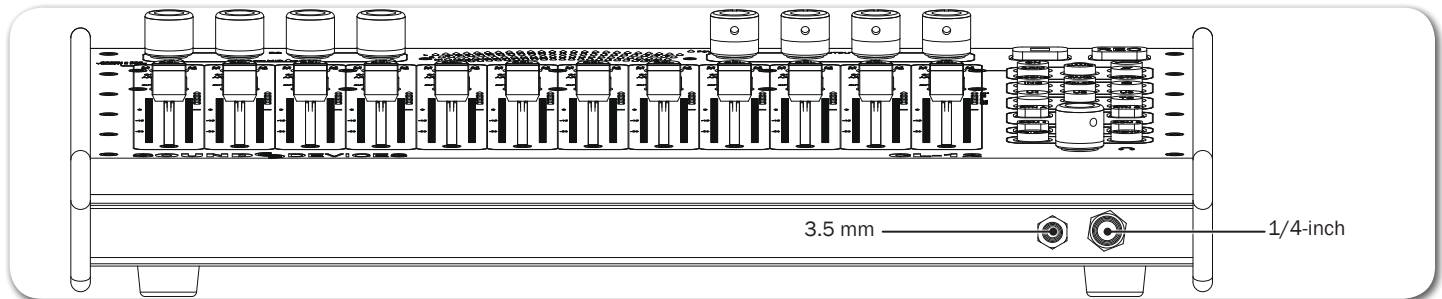

The back panel provides the connections required for attaching the CL-12 to 6-Series mixers, plus ports for other peripherals.

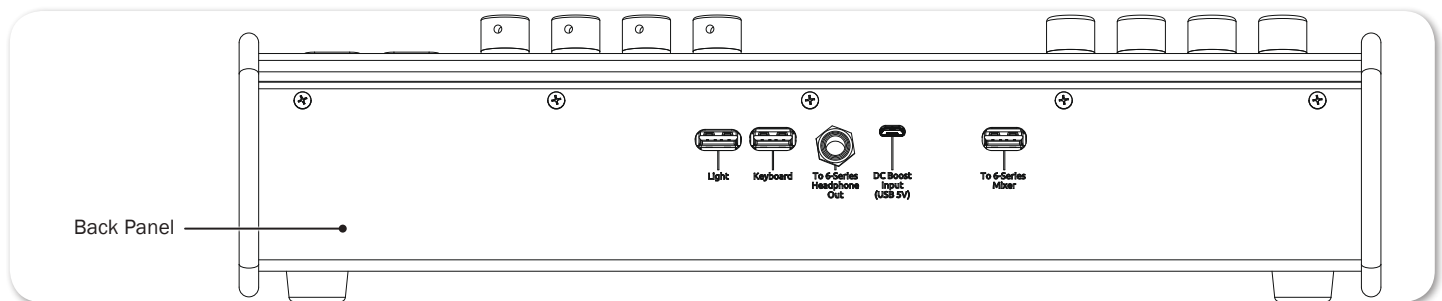

FEATURE	DESCRIPTION
Light	USB A connection for attaching an external USB light source, useful for illuminating the CL-12 surface in low light conditions.
Keyboard	USB A connection for attaching a peripheral USB keyboard, which can be used for control and entering metadata. This port may also be used to connect third-party systems for wireless remote control of 6-Series mixers. <i>ⓘ When using an external keyboard, first ensure MENU > System > USB Port is set to USB Host/Keyboard before plugging in the keyboard.</i>
Headphone Input	A $\frac{1}{4}$ -inch headphone jack for connecting the CL-12 to the mixer's $\frac{1}{4}$ -inch headphone output, making it possible to monitor audio directly from the front of the CL-12. Use the supplied $\frac{1}{4}$ -inch to $\frac{1}{4}$ -inch cable, which adds a low-resistance ground connection to the CL-12 chassis for extra robustness between the mixer and the CL-12 in the event of static shock.

FEATURE	DESCRIPTION
DC Boost Input	<p>Connect a micro USB power cord (not included with the CL-12) to this port (5V) on the CL-12 is required for connecting a CL-12 to either a 664 or 633.</p> <p>When using a CL-12 with a 688, this port is optional, but recommended for providing additional DC power when necessary, such as for powering a high-current-draw USB keyboard. Connecting additional power to this port will also allow for brighter illumination of the CL-12's buttons and LEDs.</p>
To 6-Series Mixer	<p>Connect this USB port on the CL-12 to the mixer's USB B port by using the supplied USB cable. This connection provides both control and power to the CL-12.</p> <p><i>ⓘ When the CL-12 is connected, any CL-6 attached to the mixer is disabled.</i></p>

The top panel of the CL-12 has an abundance of faders, buttons, LEDs, and controls for an intuitive mixing and control user experience.

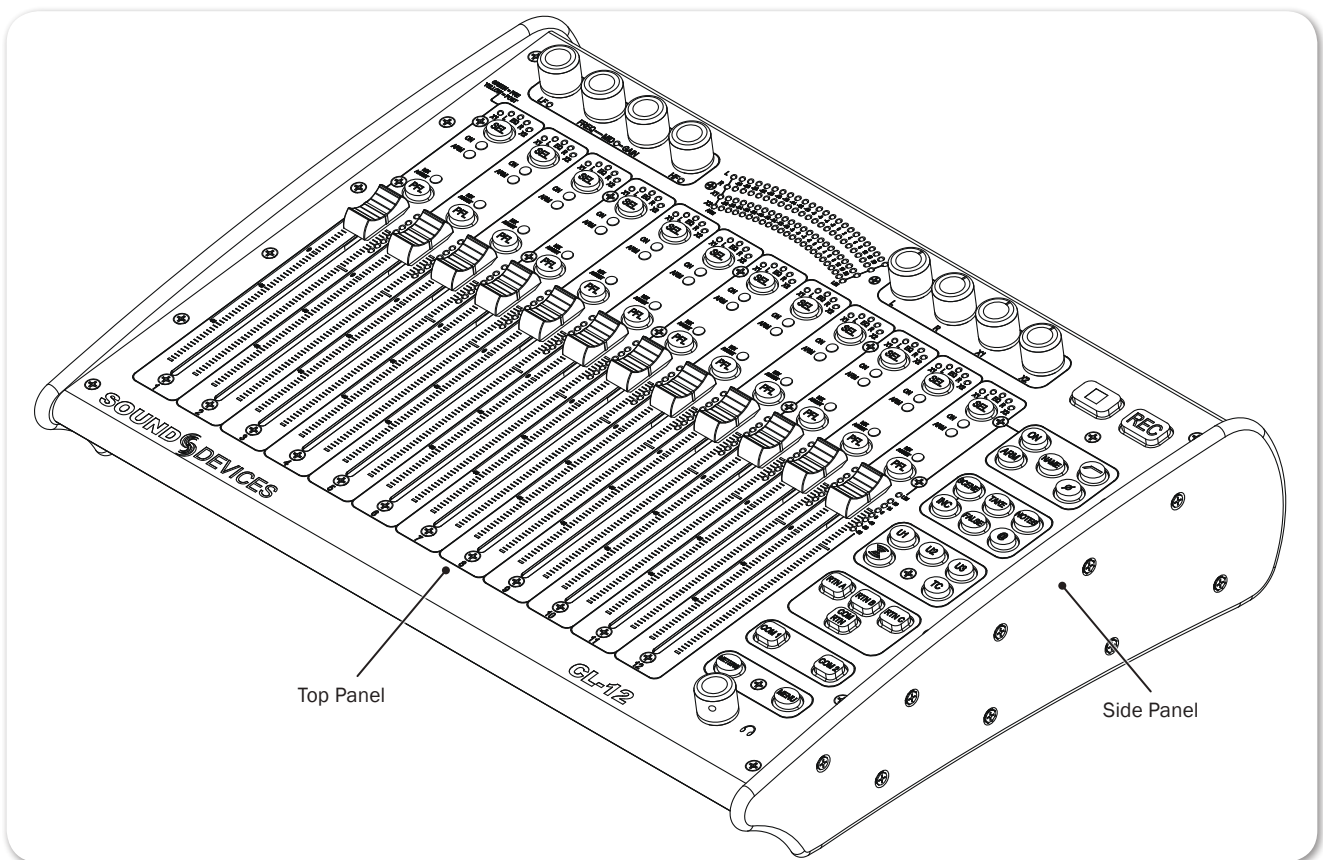

To fully explain each feature of the CL-12's top panel, the mixing surface is divided into three areas:

- Top – comprised of the EQ and OUTPUTS sections
- Left – comprised of the Channel Strip section
- Right – comprised of the Headphone encoder and several sections of buttons for various functions, such as transport control, channel selection, etc.

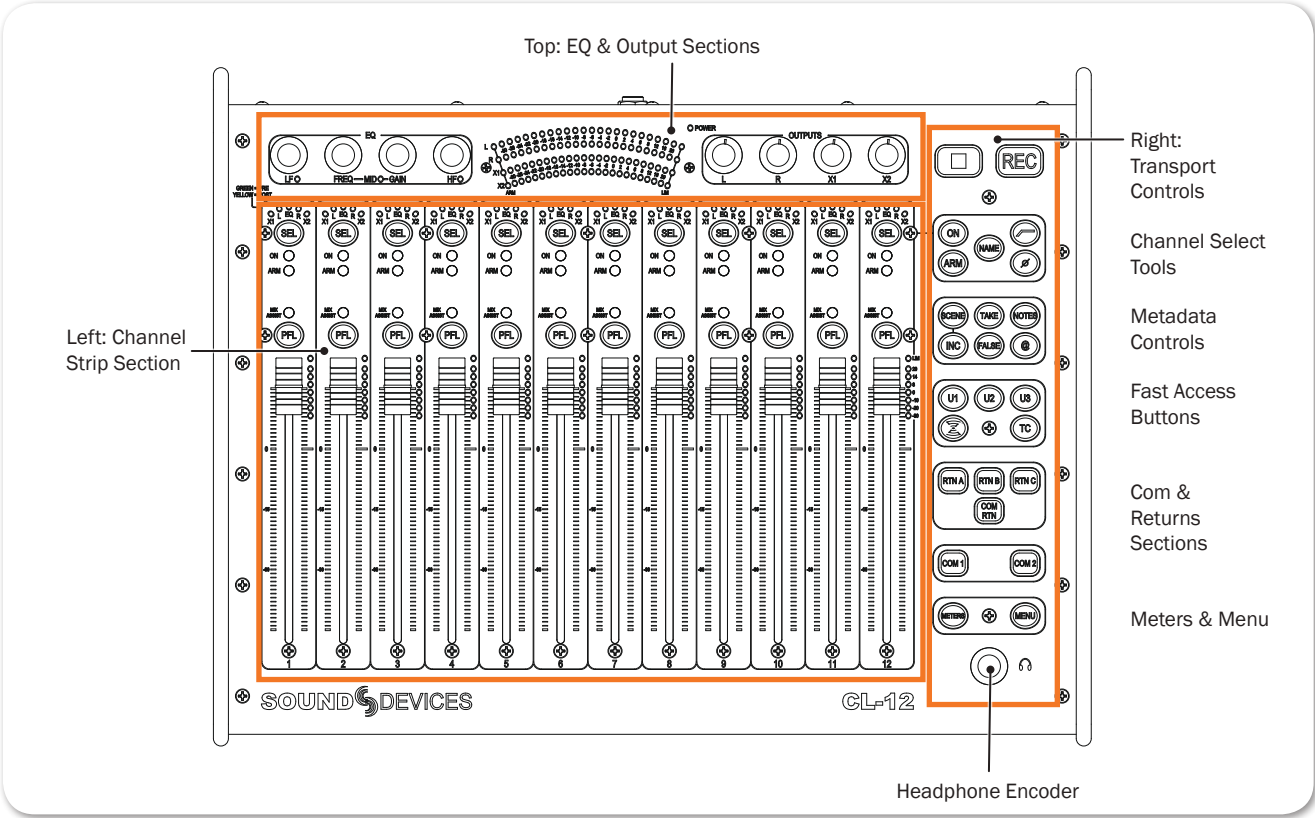

Top: EQ & OUTPUTS Sections

The area that spans the top edge of the mixing surface has rotary controls for EQ and Outputs, as well as LED metering and the Power LED.

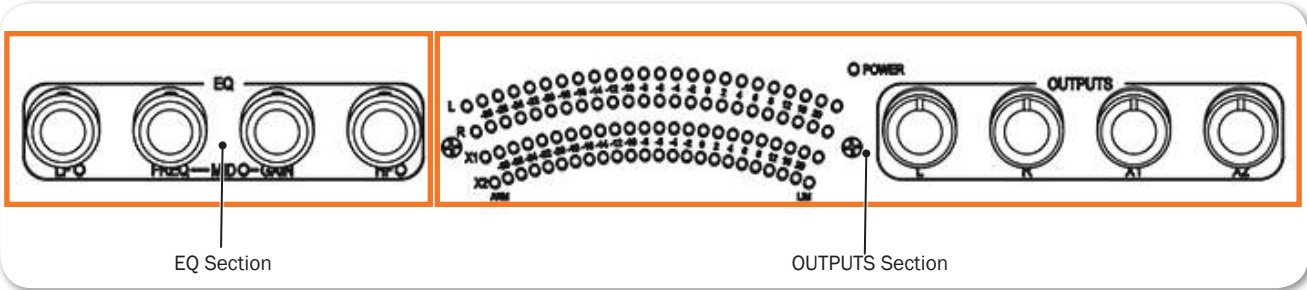

① *Not all features described here are available with every mixer. For more information, see [CL-12 Comparison Chart](#).*

FEATURE	DESCRIPTION
EQ Controls	<p>There are four rotary encoders in the EQ section. These 3-band EQ controls include LF gain, MID frequency/gain, and HF gain. Other EQ parameters, such as Q-factor and filter type are set up from the CL-12 > EQ sub-menu.</p> <p>For more information, see Using the 3-Band Equalizer (688 only), Bypassing EQ and Accessing the Submenu.</p>

FEATURE	DESCRIPTION
LED Output Meters	Displays 22-segment metering levels, as well as both ARM and LIM (limiter) LEDs for L, R, X1, and X2. ⓘ LED meters may be configured to display either output or track levels. For more information, see Configuring Output Meters (688 only) .
Power LED	Illuminates green when the CL-12 is powered on via the USB connection to an attached 6-Series mixer.
Output Controls	There are four rotary controls or “pots” in the OUTPUTS section, which may be used for routing as well as adjusting output or track levels. Press to route or arm; turn to adjust level. For more information, see Adjusting Output or Track Levels and Arming L, R, X1, X2 Tracks .

Left: Channel Strip Section

The area that spans the majority of the mixing surface comprises 12 channel strips. Each strip is comprised of 12 linear faders, SEL and PFL buttons, LED indicators and LED meters. The CL-12’s low latency faders allow for responsive level adjustment.

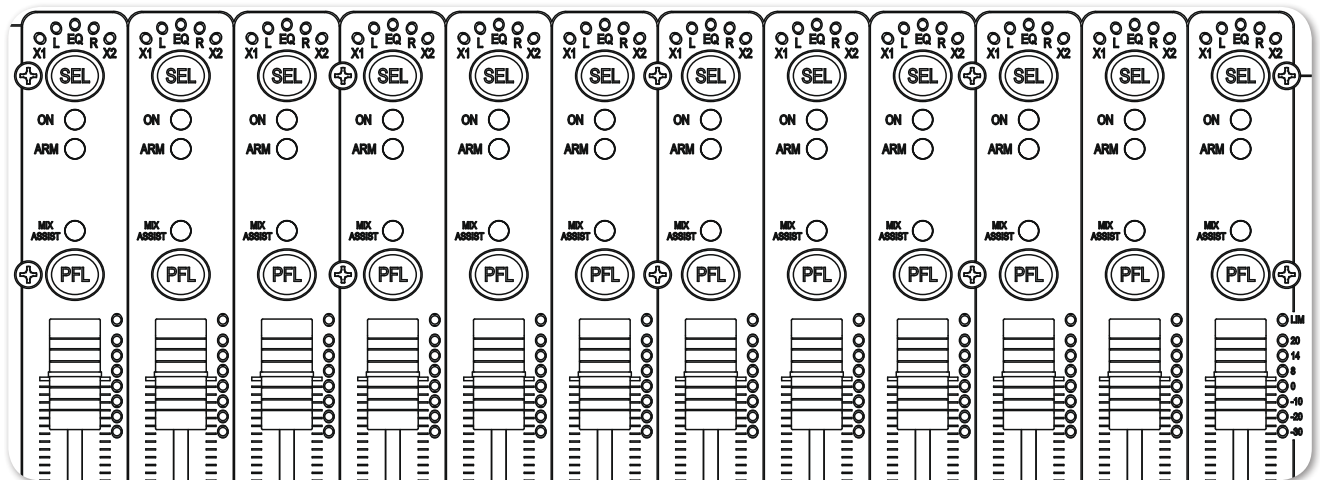

ⓘ Not all features described here are available with every mixer. For more information, see [CL-12 Comparison Chart](#).



FEATURE	DESCRIPTION
X1 Routing Indicator	Illuminates when the input channel has been routed to the X1 output. <ul style="list-style-type: none"> • Off = not routed • Green = pre-fade routing • Yellow = post-fade routing
L Routing Indicator	Illuminates when the input channel has been routed to the left bus. <ul style="list-style-type: none"> • Off = not routed • Yellow = post-fade routing
EQ LED	Indicates when some form of EQ has been applied to the input channel. Illuminates blue if any LF, MID, or HF EQ band is set to non-zero gain for the selected input.

FEATURE	DESCRIPTION
R Routing Indicator	<p>Illuminates when the input channel has been routed to the right bus.</p> <ul style="list-style-type: none"> • Off = not routed • Yellow = post-fade routing
X2 Routing Indicator	<p>Illuminates when the input channel has been routed to the X2 output.</p> <ul style="list-style-type: none"> • Off = not routed • Green = pre-fade routing • Yellow = post-fade routing
SEL Button	<p>Selects or deselects an input channel, or multiple input channels for adjustment.</p> <p>Each SEL button illuminates when a channel is selected.</p> <p>While selected, an input channel may be routed to L, R, X1 or X2. It also may be turned on, armed, or named. Additionally, high-pass filtering, phase inversion, or EQ may be applied.</p> <p>For more information, see Selecting One or More Input Channels. See also Setting SEL to follow PFL.</p>
ON Indicator	Illuminates yellow to indicate the input channel is on.
ARM Indicator	Illuminates red to indicate the corresponding isolated track (ISO) is armed for recording.
MIXASSIST Indicator	Illuminates to indicate auto-mixing activity. When the input is open, the LED is green. As the input closes, the LED is turned off.
PFL Buttons (Pre-/Post-Fade Listen)	<p>Activates or deactivates pre- or post-fade listen of inputs 1-12 to the headphone monitor.</p> <p>For more information, see Activating PFL of an Input. See also Setting SEL to follow PFL.</p>
Linear Faders	<p>100 mm low latency linear controls for adjusting the fader levels of inputs 1-12. Ranges from Off, - 80 to +16 dB.</p> <p>Each input's linear fader gain is displayed on the mixer's Input Settings screen. Calibrate linear faders to 0 dB via the mixer's SYSTEM > Fader/Pan Calibration menu.</p>
LED Meters	Displays 7-segment pre- or post-fade metering, plus pre- and post-fade limiter LED indicator for input channels 1-12.

Right: Buttons and HP Encoder

The area that spans the right side of the mixing surface has transport controls and numerous buttons for quick access to many key features. For convenience, the buttons are grouped in sections according to common functionality.

① *Not all features described here are available with every mixer. For more information, see CL-12 Comparison Chart.*

SECTION	BUTTONS	NAME	DESCRIPTION
Transport Controls		Record	While the Transport Control on the mixer operates normally when the CL-12 is attached, this alternate, backlit Record button provides an additional control for starting a recording.
		Stop	This alternate, backlit Stop button provides an additional control for stopping a recording or playback, or (when stopped) viewing the next take's file name.
Channel Select Tools		① <i>Channel Select tools operate on the currently selected channel(s).</i>	
		ON	Press to toggle a channel on or off. When on, the input's ON LED illuminates yellow.
		ARM	Press to arm or disarm the channel. When armed, the input's ARM LED illuminates red.
		NAME	Press this button to display and edit the currently selected channel's track name. This name is embedded as metadata within the recorded files. ① <i>This functionality only works when one input is selected. If multiple inputs are selected when the NAME button is pressed, a warning message appears instructing the user to select a single input.</i>
		HPF	Press to toggle on or off high-pass filtering for a selected input channel. For more information, see Using High-pass Filters .
Phase	Press to toggle the phase of a selected input channels. When inverted, the PHASE button illuminates orange.		

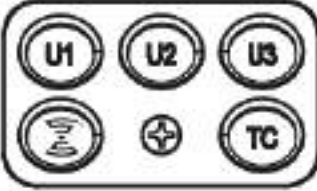
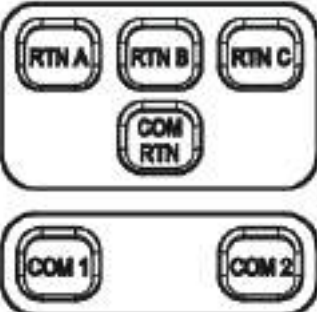
SECTION	BUTTONS	NAME	DESCRIPTION
Metadata Controls		<p>① Use the on-screen, virtual keyboard or a USB keyboard plugged into the back panel of the CL-12 to edit metadata.</p> <p>All edits update the relevant embedded metadata within the file and file name.</p>	
		SCENE	While recording, press to display and edit the current scene name. While stopped, press to display and edit the next scene name. Press SCENE again to save and exit.
		TAKE	While recording, press to display and edit the current take's Take number. While stopped, press to display and edit the next take's Take number. Press TAKE again to save and exit, or select Done.
		NOTES	While recording, press to display and edit the current take's Notes. While stopped, press to display and edit the next take's Notes. Press NOTES again to save and exit.
		INC	① Hold NOTES button down for 1 second to view Phrase List screen.
		FALSE	Increments the scene name according to settings configured via File Storage > Scene Increment Mode.
		@	Moves last take to the False Takes folder and decrements the take number by 1.
Fast Access		U1, U2, U3	User definable buttons. These may be configured to many different functions in the CL-12 sub-menu.
		SuperSlot	Displays the SL-6 Receiver Overview screen, should an SL-6 be connected.
		TC	Displays the Timecode Jam menu.
COM & Return Controls		RTN A, RTN B, RTN C	Press the button corresponding to the A, B, or C return feed to be monitored in the headphones.
		COM RTN	Press to monitor COM return in the headphones.
		COM 1, COM 2	Activates the selected COM (1 or 2)
		①	Both may be operated simultaneously.

SECTION	BUTTONS	NAME	DESCRIPTION
Meters & Menu		METERS	Duplicates the functionality of the mixer's METERS button.
		MENU	Duplicates the functionality of the mixer's MENU button.

Altered Functionality

When the CL-12 is connected to a 6-Series mixer, some mixer functionality is changed. The following table indicates the functionality and which mixers are affected.

FUNCTIONALITY	688	664	633
New CL-12 submenu is enabled	✓	✓	✓
INPUTS > PFL Toggle Mode submenu is disabled	✓	✓	✓
<i>① On the 664, the submenu is called INPUTS > Input Mode.</i>			
Rotary faders (1-6) disabled	✓	✓	✓
Rotary faders (7-12) become trim controls for (7-12)	✓	—	N/A
L, R, X1, X2 adjustment via SELECT encoder is disabled	✓	✓	✓
CL-6 Rotary faders (7-12) disabled	✓	✓	N/A

Feature Comparison Chart

Feature availability is contingent on the model of the mixer to which the CL-12 is connected. The following table outlines the differences between the various 6-Series models.

CL-12 FEATURE	688	664	633
Number of linear faders	12	12	6
DC Boost micro USB power connection	Optional	Required	Required
3-band semi-parametric equalizer	✓	—	—
Auto Mixer Metering and Control	✓	—	—
SuperSlot Control	✓	—	—
COMs	1 & 2	1	—
Returns	A,B,C	A,B,C	A
Slate + Tone (via User Programmable buttons)	✓	✓	✓
SL-6 Routing (via User Programmable buttons)	✓	—	—
LR, X1, X2 Track Level Control & Metering	✓	✓	✓
Physical LR, X1, X2 Output Level Control & Metering	✓	—	—
7-segment PFL Metering + Limiter Activity	✓	✓	✓
Channel On/Off	✓	✓	✓
Headphone Level & Preset	✓	✓	✓
HPF Control	✓	7-12 only	✓

CL-12 FEATURE	688	664	633
Input Phase Control	✓	ch 2,4,6 only	ch 2 only
Input PFL and SEL Controls	✓	✓	✓
Input Routing to LR, X1, and X2	✓	✓	✓
Menu Control	✓	✓	✓
Metadata Control	✓	✓	✓
Track Arming & Naming	✓	✓	✓
Transport Control	✓	✓	✓
USB Peripherals (Light & Keyboard)	✓	✓	✓
User Programmable buttons (U1, U2, U3)	✓	✓	✓

CL-12 Sub-menu

When the CL-12 is attached to a 6-Series mixer, a new CL-12 sub-menu is available via the Main menu. Options in the menu will vary based on the mixer’s model. For instance, the left image, shown below, is the menu as it appears on a 688. The right image is the menu as it appears on a 664 or 633.

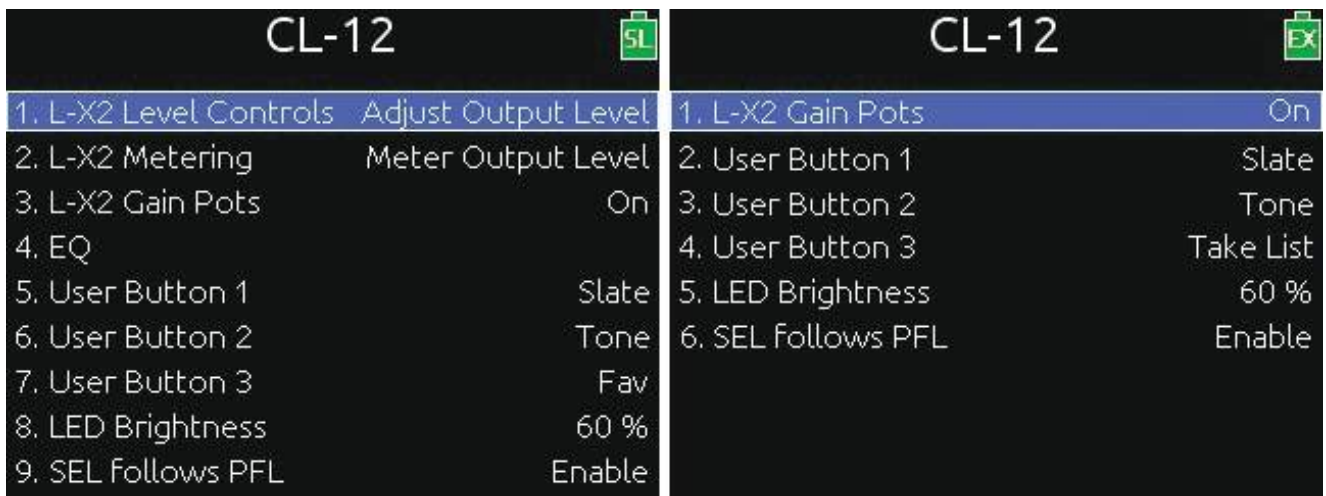

OPTION	DESCRIPTION
L - X2 Level Controls	Configure level controls to control either output or track levels. Since the 664 and 633 only allow for control of track levels, this menu option is not available when a CL-12 is connected to them. For more information, see Adjusting Output or Track Levels .
L - X2 Metering	Configure LED meters to display either output or track levels. Since the 664 and 633 only allow for metering of track levels, this menu option is not available when a CL-12 is connected to them. For more information, see Configuring Output Meters (688 only) .
L - X2 Gain Pots	Enables/disables the L, R, X1 and X2 controls on the CL-12 (OUTPUTS section).
EQ	Displays submenu related to EQ, a feature only available with the 688. For more information, see Accessing the EQ Submenu .
User Button 1	Set function of U1 button.
User Button 2	Set function of U2 button.

OPTION	DESCRIPTION
User Button 3	Set function of U3 button. For more information, see Configuring User Programmable Buttons .
LED Brightness	Set brightness of CL-12 LEDs. For more information, see Adjusting CL-12's LED Brightness .
SEL follows PFL	Enables or disables automatic selection of an input channel when its PFL button is pressed. When enabled, pressing PFL will illuminate both the PFL and SEL button for the chosen input channel. For more information, see Setting SEL to follow PFL .

Selecting One or More Input Channels

Input channels may be selected individually or as a group for group adjustment. One or more input channels may also be added to any previously selected group. Parameters that can be adjusted when an input channel's SEL button is selected are: ON, ARM, NAME, HPF, PHASE, EQ, and Routing to L, R, X1, X2.

① *NAME and EQ can only be adjusted for a single channel.*

To select an input channel:

▶ Press the input's SEL button.

① *Press the input's SEL button again to deselect it, or press any other SEL button to change selection.*

To select multiple input channels, do either of the following:

▶ Simultaneously press multiple SEL buttons.

▶ Press and hold one SEL button down while then pressing one or more SEL buttons for other required inputs.

① *Press any single illuminated SEL button to simultaneously deselect the group.*

To add more input channels to a selected group:

▶ Press and hold an illuminated SEL button while pressing any additional SEL buttons to add those input channels to the group.

Activating PFL of an Input

Pre- or post-fade listen may be activated on one input at a time.

To PFL an input:

- ▶ Press the input's PFL button.

There are two modes of PFL: momentary and latching.

MODES	DESCRIPTION
Momentary	If the PFL button is held for greater than one second, PFL only remains active for as long as the button is held. The mixer's LCD does not change screen.
Latching	If the PFL button is quickly tapped, PFL is "latched" on until the PFL button is tapped again or another is selected. When active, the PFL button illuminates, and the Input Settings screen for the active PFL input is displayed on the mixer's LCD.

Setting SEL to follow PFL

The CL-12 provides the SEL follows PFL option for automatic selection of an input channel when its PFL button is pressed. Think of SEL follows PFL as a fast, one-touch method for gaining access to PFL, the Input Settings screen, EQ, routing, and channel select tools. This feature may be disabled so that PFL activation and input channel selection are independent.

To enable or disable SEL follows PFL:

1. Press MENU.
2. Select CL-12 > SEL follows PFL.
3. Select one of two options: Enable and Disable.

Trim Level Adjustment on 6-Series

For inputs 1 through 6, on either the 688 or the 664, trim is still adjusted via the dedicated rotary Trim controls on the mixer, even when the CL-12 is attached. Likewise, on the 633, for inputs 1 through 3, trim is adjusted via the dedicated rotary Trim controls.

However, trim level adjustment of other inputs varies depending on the different designs of each 6-Series mixer to which the CL-12 is attached. For instance, adjusting trim on input 7 of a 688 is not the same as adjusting trim on input 7 of a 664.

The following sub-sections provide details and procedures for adjusting trim levels on inputs 7-12 on the 688, inputs 7-12 on the 664, and inputs 4-6 on the 633.

Adjusting Trim Levels (688 only)

When the CL-12 is attached to the 688, the mini-faders on the 688 become dedicated trim controls for inputs 7-12.

To adjust the trim level for inputs 7-12:

- ▶ Turn the appropriate mini-fader on the 688. The trim gain is displayed on the mixer's LCD via the Input Settings screen.

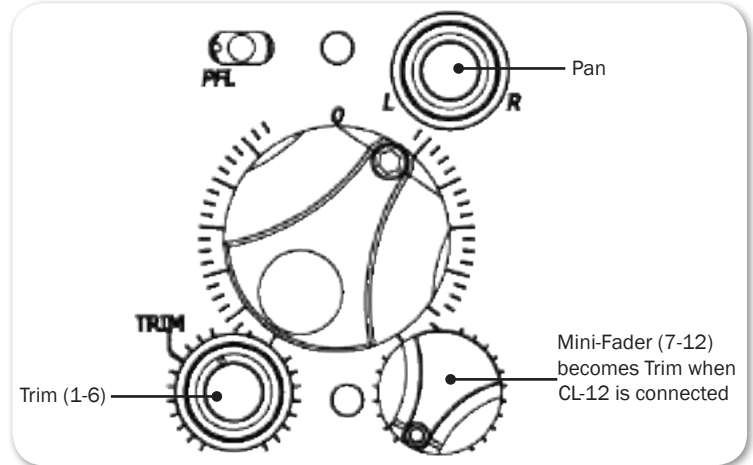

Adjusting Trim Levels (664 only)

When the CL-12 is attached to the 664, the mixer's SELECT encoder may be used to adjust trim for inputs 7-12 via the Input Settings screen.

To adjust the trim level for inputs 7-12:

1. Slide the input's PFL switch on the CL-6 to the right to access the Input Settings screen on the mixer's LCD.
2. Turn the SELECT encoder to adjust trim for the input. The trim gain is displayed on the mixer's LCD.

Adjusting Trim Levels (633 only)

When the CL-12 is attached to the 633, the mini-faders on the 633 become dedicated trim controls for inputs 4-6.

To adjust the trim level for inputs 4-6:

- ▶ Turn the appropriate mini-fader on the 633. The trim gain is displayed on the mixer's LCD via the Input Settings screen.

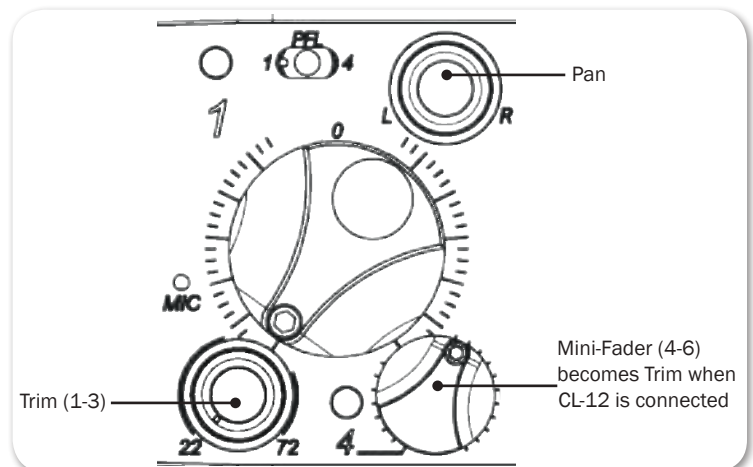

Routing Input Channels

With the CL-12, routing input channels to the left or right mix bus and the X1 or X2 output is quick and easy.

To route an input channel or multiple input channels:

1. Do either of the following:
 - ▶ Press the input channel's SEL button.
 - ▶ Select multiple input channels, using their SEL buttons.
2. Press the L, R, X1 or X2 output control to route to L, R, X1 or X2, respectively.

Routing to X1 or X2 can be pre- or post-fade. Press the X1 or X2 output control to cycle through the options: Route Off, Route Pre-fade, Route Post-fade. When routing is pre-fade, the X1 and X2 LEDs illuminate green. When routing is post-fade, the LEDs are yellow.

- ① *Alternatively, you can press and hold an L, R, X1, or X2 control, and then press one or more SEL button(s) for the input channel(s) you want to route to that output.*
- ① *TIP: For continuous pan control, set an input channel's routing to both L and R, then use the Pan control on the 6-Series mixer to smoothly adjust pan. This will ensure that an input's pan position will be retained when disconnecting and reconnecting the CL-12.*

Adjusting Output or Track Levels

The CL-12 has four rotary controls labeled OUTPUTS that are used for adjusting either output or track levels, based on which mixer is connected to the CL-12 and how the controls are configured.

On the 633 and 664, the CL-12's Output controls are used for adjusting track levels for L, R, X1, and X2.

On the 688, however, the CL-12's Output controls may be configured to adjust either output or track levels for L, R, X1, and X2.

To configure CL-12 output controls:

1. Press MENU to access the 688's Main menu.
2. Select CL-12 > L - X2 Level Controls.
3. Select one of two options: Adjust Output Level or Adjust Track Level.

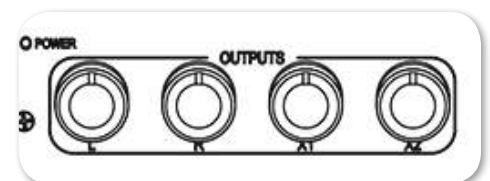

To adjust levels:

- ▶ Turn the Output control corresponding to which level you want to adjust: L, R, X1, or X2. The level value is displayed on the mixer's LCD in the HP field.

- ① *When L and R are linked, L controls level for the L/R output pair. When X1 and X2 are linked, X1 controls level for both. Also, when linked, the R and X2 controls are disabled. (Output linking control is in the OUTPUT menu.)*

Configuring Output Meters (688 only)

On a 688, the LED output meters on the CL-12 may be configured to meter L, R, X1, and X2 output or track levels. For other 6-Series mixers, the 22-segment output metering on the CL-12 is always for track levels.

To configure CL-12 output meters:

1. Press MENU to access the 688's Main menu.
2. Select CL-12 > L - X2 Metering.
3. Select one of two options: Meter Output Level or Meter Track Level.

Disabling Output Controls

The 6-Series mixers, when attached to a CL-12, has a sub-menu option that lets users disable the rotary output level controls for L, R, X1, and X2 to avoid accidental changes in level.

To disable the output controls on the CL-12:

1. Press MENU.
2. Select CL-12 > L-X2 Gain Pots.
3. Select Off. This setting is On by default.

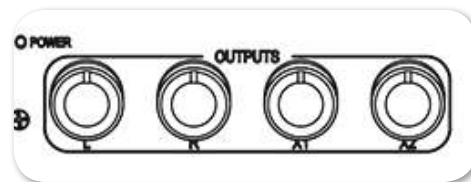

- ① *Even when disabled, users can still route to L, R, X1, and X2 by pressing in the controls (pots). Also, disabling the CL-12 output level controls does not impact controls on the mixer. Attenuation of output may still be achieved via the mixer.*

Arming L, R, X1, X2 Tracks

With the CL-12, L, R, X1 and X2 may be armed for recording, or unarmed.

To arm L, R, X1, X2 tracks for recording:

1. Press and hold down the ARM button.
2. Press the rotary OUTPUT control(s) corresponding to the output track(s) you want to arm.

When armed, each output track's ARM LED illuminates red.

Using the 3-Band Equalizer (688 only)

The CL-12 adds 3-band EQ to the 688. EQ is only available when sample rate is 48.048 kHz or less, and it is only available for adjustment when CL-12 is connected.

- LF is a fixed 100 Hz EQ by default, with +/- 12 dB gain adjustment. The default may be altered via settings in the EQ submenu.
- MID provides variable EQ frequency adjustment over 400 Hz – 6k range with +/- 12 dB gain adjustment.
- HF is a fixed 10 kHz EQ by default, with +/- 12 dB gain adjustment. The default may be altered via settings in the EQ submenu.

① *When CL-12 is disconnected, the EQ settings are retained, but they cannot be adjusted. For more information, see [Accessing the EQ Submenu](#).*

To adjust EQ for a selected input, do any of the following:

- ▶ Turn the LF encoder to adjust the selected input's low frequency gain.
- ▶ Turn the FREQ encoder to adjust the selected input's MID frequency.
- ▶ Turn the GAIN encoder to adjust the selected input's MID gain.
- ▶ Turn the HF encoder to adjust the selected input's high frequency gain.

Above the SEL button for each input, the EQ LED illuminates blue when any of the LF, MID, or HF are set to non-zero gain, giving a quick global indication that some form of equalizer is applied to the input(s).

If a selected input has LF applied, the LF LED illuminates orange.

If a selected input has MF applied, the MID LED illuminates yellow, and if a selected input has HF applied, the HF LED illuminates green.

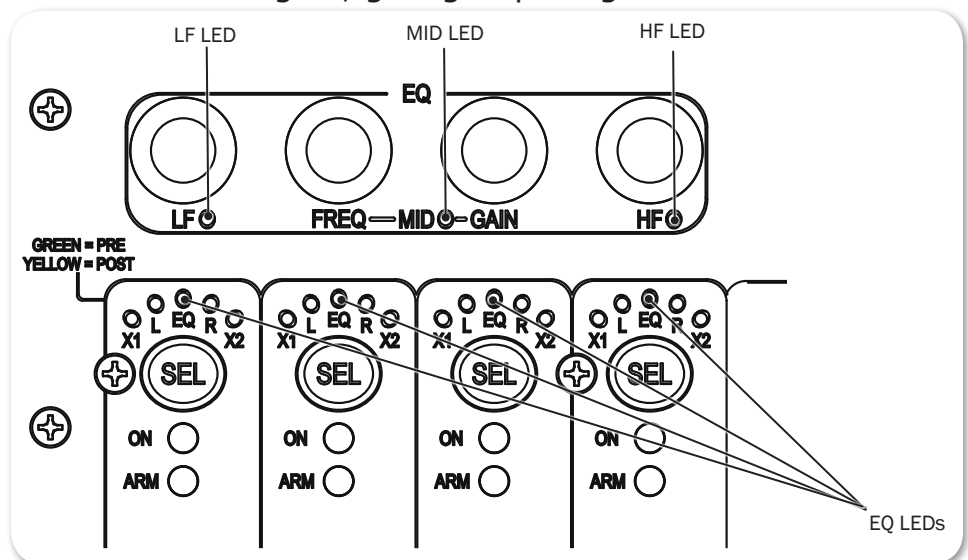

When EQ is applied to a selected input, the EQ screen also appears for the selected input on the mixer's LCD. For instance, in the following example, EQ is applied to channel 1 (CH-1); LF is set at 10 dB and HF is set to -10 dB, while MID frequency and gain are bypassed. In the example, high-pass filtering is off, the Q-factor is set to 1.0 and both LF and HF filtering is set to Peaking.

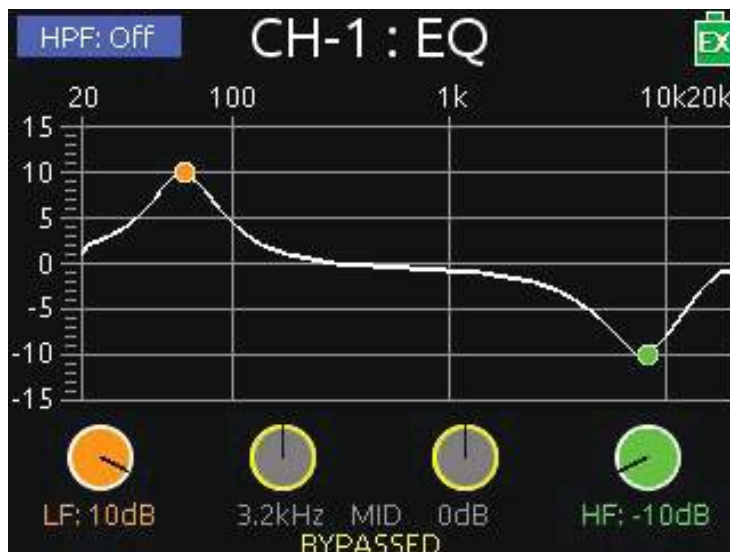

It is not possible to adjust EQ for multiple inputs at the same time. When multiple input channels are selected, the channel that is adjusted will be the last one added to the group.

There is a 10-second timeout on the EQ screen, if nothing is adjusted.

- ① *Press and hold an input's SEL button while pressing any of the EQ encoders to view the input's EQ screen without changing the input's EQ value.*

Accessing the EQ Submenu

Several settings related to EQ—such as Q-factor, EQ routing, and so forth—may be configured via the EQ submenu.

To access the EQ submenu:

1. Press MENU.
2. Select CL-12 > EQ. The EQ submenu appears.

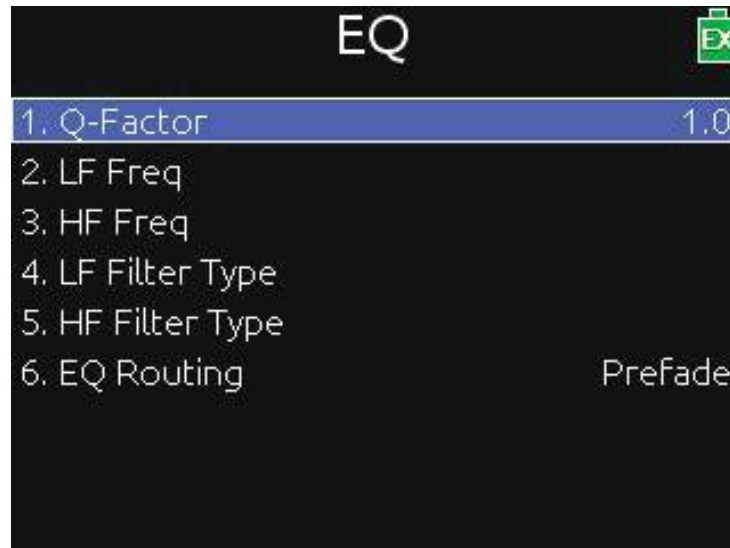

OPTION	DESCRIPTION
Q-Factor	Set to one of four values: 0.707, 1.0, 1.414, 2.0. This affects all EQ bands. For more information, see Setting the Q-Factor .
LF Freq	Values range from 60 Hz to 300 Hz. Default is 100 Hz. This may be adjusted individually for each channel.
HF Freq	Values range from 8 kHz to 16 kHz. Default is 10 kHz. This may be adjusted individually for each channel. For more information, see Setting LF and HF Frequency Defaults .
LF Filter Type	Set to either Peaking or Shelving. This may be adjusted individually for each channel.
HF Filter Type	Set to either Peaking or Shelving. This may be adjusted individually for each channel. For more information, see Setting LF and HF Filter Types .
EQ Routing	Set to either Pre-fade or Post-fade. This affects all input channels. For more information, see Setting EQ Routing .

Bypassing EQ

When necessary, it is possible to temporarily and quickly bypass the application of EQ without altering the current non-zero gain value. The label **BYPASSED** is shown on the EQ screen for any band that is bypassed.

To bypass EQ do any of the following:

- ▶ Press the LF encoder.
- ▶ Press the FREQ or GAIN encoder.
- ▶ Press the HF encoder.

These controls act as toggles between bypass (gain = 0 dB) and the last non-zero gain value, so pressing any encoder a second time will toggle off bypass and reapply the last non-zero gain value for LF, MID, or HF respectively.

When an EQ band is bypassed, its EQ LED goes out.

Setting the Q-Factor

The Q-factor controls the bandwidth that will be cut or boosted by the equalizer.

To set the Q-factor:

1. Press MENU.
2. Select CL-12 > EQ > Q-Factor.
3. Select one of the following options: 0.707, 1.0, 1.414, or 2.0.

The lower the setting, the wider the bandwidth, which means more frequencies will be affected by EQ. The higher the setting, the narrower the bandwidth, so the EQ adjustment will be more selective.

For example, the following two images show a 10 dB LF peaking filter applied to CH-1; however, the Q-factor for the left one is set to 0.707, while the Q-factor for the right one is set to 2.0.

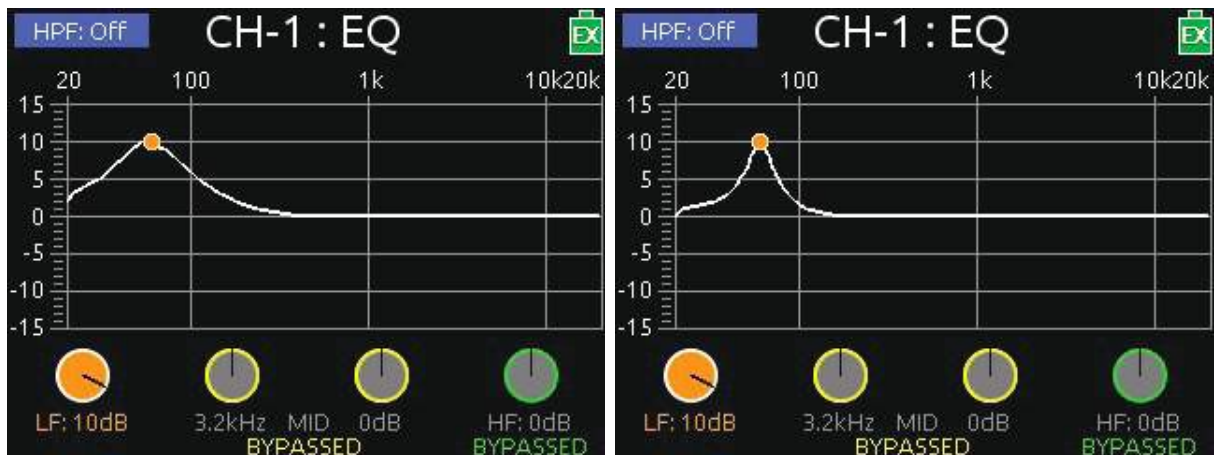

Setting LF and HF Frequency Defaults

The default for LF is 100 Hz and the default for HF is 10 kHz, but both may be adjusted for each individual input via setting in the EQ submenu.

To adjust LF and HF Freq. defaults:

1. Press MENU.
2. Select CL-12 > EQ.
3. Do the following:
 - ▶ Select LF Freq and set a new value. Options include values in increments of 10 from a minimum 60 Hz to maximum 300 Hz.
 - ▶ Select HF Freq and set a new value. Options include values in increments of 10 from a minimum 8 kHz to maximum 16 kHz.

Setting LF and HF Filter Types

The CL-12's EQ offers two types of filters: Peaking and Shelving, and these may be adjusted individually for each input.

FILTER	SAMPLE IMAGE	DESCRIPTION
Peaking		A peaking filter will create a hill- or peak-like boost or cut around a particular frequency. The spread of the "peak" will vary based on the Q-factor.
Shelving		A shelving filter will slope up or down to a particular point and remain constant at its level of boost or cut.
		The sample image shows examples of both shelving (LF) and peaking (HF).

To set type of LF and HF filters:

1. Press MENU.
2. Select CL-12 > EQ.
3. Do the following:
 - ▶ Select LF Filter Type and set each input to either Peaking or Shelving.
 - ▶ Select HF Filter Type and set each input to either Peaking or Shelving.

Setting EQ Routing

EQ may be applied either pre- or post-fade. This setting globally affects all inputs.

To set EQ routing:

1. Press MENU.
2. Select CL-12 > EQ > EQ Routing. Options include: Pre-fade or Post-fade.

Using High-pass Filters

The High-pass Filter (HPF) button on the CL-12 is a toggle, which turns the high-pass filter off or on for the selected input.

On the 664, since inputs 1-6 are analog, the CL-12's HPF button toggles on or off high-pass filtering for inputs 7-12 only at the fixed frequency of 150 Hz.

On the 688 and 633, the high-pass filter may be adjusted for all inputs to other frequencies.

To turn on and adjust an input's high-pass filter:

1. Select an input, using the input's SEL button.
2. Press the HPF button.
 - ① *If inputs 1-6 are selected on the 664 when the CL-12's HPF button is pressed, a message will appear: "Use the low-cut control on the 664 front panel."*

The HPF button illuminates when high-pass filtering is on.

3. (633 & 688 only) Adjust the HPF value via the Input Settings screen.

When high-pass filtering is on, the HPF value is fixed at 150 Hz on the 664, but may be changed via in the Input Settings screen on the 633 or 688. Also, on the 688, the EQ screen appears on the mixer's LCD. The Headphone encoder may be used as an alternative way to adjust the HPF value displayed on the EQ screen.

- ① *Press the HPF button again to turn off the high-pass filter.*

Naming Tracks

Since inputs are hard-wired to their respective tracks, the input name is the same as the track name. Naming functionality only applies to one selected input at a time. Attempting to do so with multiple inputs selected will result in a message instructing the user to select a single input before continuing.

While recording, the current take's track name may be modified. Edits to the track name in the current take will also be applied to the next take and subsequent recordings that follow. The next take's track name may be edited so long as recording is stopped.

To enter or edit track names:

1. With a single input selected, press the NAME button. The Track Name List appears over the Meters View.
2. Do any of the following:
 - ▶ Select Edit Entry to edit the current entry.
 - ▶ Select Add New Entry to enter a new track name.
 - ▶ Select a name from the list.

① *TIP: Prepare a list of names to use for fast selection during production.*

Configuring User Programmable Buttons

The CL-12 offers three user programmable buttons for quick-access to a wide range of functions and menus.

To configure U1 – U3 buttons:

1. Press MENU.
2. Select CL-12 > User 1-3 buttons.
3. Select an option to assign to the button. The following table shows possible options and whether they are available with the different 6-Series mixers:

OPTION	DESCRIPTION	688	664	633
Take List	Displays the Take List screen.	✓	✓	✓
File List	Displays the File List screen.	✓	✓	✓
Play	Toggles between play and pause.	✓	✓	✓
FFWD	Fast forward or skip to next file.	✓	✓	✓
REW	Rewind or skip to previous file.	✓	✓	✓
Slate	Toggles slate on and off.	✓	✓	✓
Tone	Toggles tone on and off.	✓	✓	✓
FAV	Duplicates the action of the FAV switch.	✓	—	✓
Select	Duplicates the action of pressing the Select encoder.	✓	✓	✓
Default Playback Card	Shortcut to FILE STORAGE > Default Playback Card sub-menu.	✓	✓	✓
Power Menu	Displays the POWER settings.	✓	—	✓
Input Delays	Displays the Input Delays screen.	✓	—	✓
Output Delays	Displays the Output Delays screen.	✓	—	✓
LR Linking	Toggles linking of L and R.	✓	✓	✓
X1/X2 Linking	Toggles linking of X1 and X2.	✓	✓	✓
Auto Mixer	Toggles the Auto Mixer (MixAssist or Dugan) on and off.	✓	—	—
Return Loopback Mode A - C	Three options: Enters Return Loopback modes for either RTN A, RTN B, or RTN C, respectively.	✓	—	—
SLATE ROUTING	Displays the Slate Routing screen.	✓	—	✓
TONE ROUTING	Displays the Tone Routing screen.	✓	—	✓
Timecode Menu	Displays the Timecode/Sync menu.	✓	✓	✓
Daylight Mode	Toggles daylight mode.	✓	✓	✓
Create Sound Report	Creates a sound report (.csv file).	✓	✓	✓
Sound Report Info	Displays the Sound Report Info screen.	✓	✓	✓
X1 - X6 Routing	Six options: Each one is a shortcut to OUTPUTS > X1-X6 Routing > X1 Routing, X2 Routing, and so forth, respectively.	✓	—	X1-X4 only
SL-6 Routing	Displays the SL-6 Routing screen.	✓	—	—
AES Routing	Displays the AES Output Routing screen.	✓	✓	✓
EQ Menu	Shortcut to CL-12 > EQ sub-menu.	✓	—	—
LF Freq	Displays the EQ LF FREQ settings.	✓	—	—
HF Freq	Displays the EQ HF FREQ settings.	✓	—	—

Adjusting CL-12's LED Brightness

Depending on the work environment, the brightness of the CL-12's LED may require adjustment.

To adjust LED brightness:

1. Press MENU and scroll to CL-12.
2. Select LED Brightness.
3. Turn the Headphone encoder to adjust value up or down in 1% increments from a minimum of 5% up to 100%.

① *TIP: LED brightness may be further boosted by connecting a USB 5 V source to the DC Boost Input port on the back panel of the CL-12.*

Replacing Side Panels

The CL-12 Alaia comes equipped with custom, hand-crafted hardwood side panels; however, included with the CL-12 Alaia is the Aluminum Endcap Kit, which contains a set of black aluminum side panels like those on the standard CL-12 model.

To replace the wood with metal side panels:

1. Use the 1/16-inch hex L key, supplied with the kit, to remove the 9 button-head screws and washers from each side of the CL-12 Alaia. The wood side panels will then come off.
2. Position each black aluminum side panel so that the holes in the panel are aligned with threaded holes in the CL-12 Alaia's chassis.
3. Use the screws, supplied with the kit, to fasten the panels, and tighten with a Phillips-head screwdriver (not supplied).

Specifications

The following specifications apply to the CL-12.

NAME	DESCRIPTION	
External Power	<ul style="list-style-type: none"> Powered by the mixer via USB cable 5V micro USB DC boost input (required for use with 664 or 633) 	
Current Draw	<ul style="list-style-type: none"> 90mA @5V typical 	
Light	<ul style="list-style-type: none"> 100 mA (when powered by 688) 500 mA (when powered with external USB power supply) 	
Size (W x D x H)	CL-12 <ul style="list-style-type: none"> 14.7 in x 11.3 in x 3.8 in 37.3 cm x 28.7 cm x 9.6 cm 	CL-12 Alaia <ul style="list-style-type: none"> 15.2 in x 11.3 in x 3.8 in 38.6 cm x 28.7 cm x 9.6 cm
Weight	<ul style="list-style-type: none"> 5 lbs 2.27 kg 	<ul style="list-style-type: none"> 5 lbs 2.27 kg

SOUND DEVICES

Sound Devices, LLC
E7556 Road 23 and 33
Reedsburg, Wisconsin 53959
USA

Phone: +1 (608) 524-0625
Fax: +1 (608) 524-0655

Customer Support

Toll Free: (800) 505-0625

Email: support@sounddevices.com
<http://www.sounddevices.com/support>
<http://forum.sounddevices.com>

Product Information

For more information about products and accessories, visit us on the web at www.sounddevices.com.

Report Documentation Error

Email: techpubs@sounddevices.com