

Operators Guide

Pro-Ped

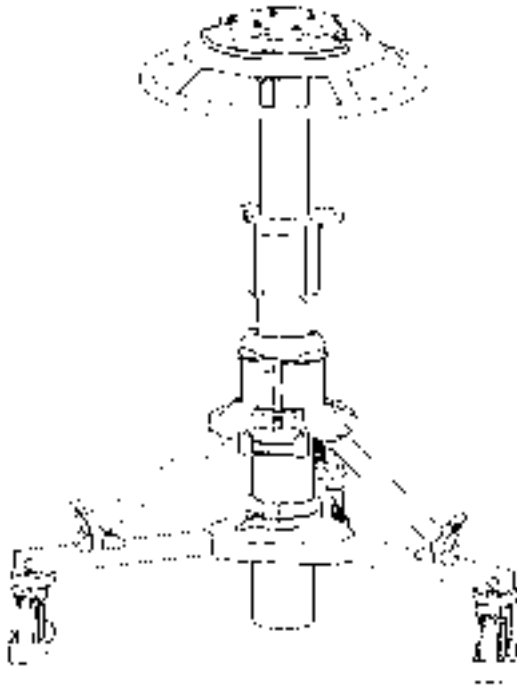

Pedestal



Vinten
Camera Control Solutions

Pro-Ped Pedestal

Publication Part No. 3983-8 Issue 6

Copyright © Vinten Broadcast Limited 2002

All rights reserved throughout the world. No part of this document may be stored in a retrieval system, transmitted, copied or reproduced in any way including, but not limited to, photocopy, photograph, magnetic or other record without the prior agreement and permission in writing of
Vinten Broadcast Limited.

Vinten is a registered trademarks of Vinten Broadcast Limited.

Safety - read this first

Warning Symbols in this Operators Guide



Where there is a risk of personal injury, injury to others, or damage to the pedestal or associated equipment, comments appear, highlighted by the word **WARNING!** and supported by the warning triangle symbol.

Warning symbols on the pedestal



On encountering the warning triangle and open book symbols it is imperative that you consult this operators guide before using this pedestal or attempting any adjustment or repair.

Critical data

Mass

Column	19 kg (41.8 lb)
Trim weights (6 off) total	3.4 kg (7.5 lb)
Skid	9.4 kg (20.7 lb)

Load

Maximum load	55 kg (120 lb)
--------------	----------------

Pressure

Maximum pressure	9.65 bar (140 psi)
------------------	--------------------

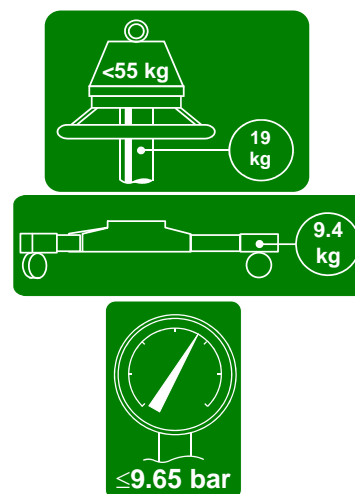

Technical data

	Studio	OB
Payload	55 kg (120 lb)	55 kg (120 lb)
Column weight	19 kg (41.8 lb)	19 kg (41.8 lb)
Skid weight	9.4 kg (20.7 lb)	9 kg (19.8 lb)
Trim weights (6 off - total)	3.4 kg (7.5 lb)	3.4 kg (7.5 lb)
Total pedestal weight	31.8 kg (70 lb)	31.4 kg (69.1 lb)
Minimum height	66.6 cm (26.2 in.)	68.5 cm (27 in.)
Maximum height	147.5 cm (58.1 in.)	150 cm (59.1 in.)
On-shot stroke	41 cm (16.1 in.)	41 cm (16.1 in.)
Skid leg radius	48 cm (19 in.)	48 cm (19 in.)
Doorway tracking width	97 cm (38 in.)	97 cm (38 in.)
Transit doorway width	86 cm (34 in.)	86 cm (34 in.)
Narrow doorway width	70 cm (27.5 in.)	70 cm (27.5 in.)
Wheel diameter	12.5 cm (5 in.)	15 cm (6 in.)
Steering ring diameter	53.4 cm (21 in.)	53.4 cm (21 in.)
Max working pressure	9.65 bar (140 psi)	9.65 bar (140 psi)
Relief valve pressure	11.38 bar (165 psi)	11.38 bar (165 psi)

Usage

The Pro-Ped Pedestal is designed for use in television studios and on location to support and balance a pan and tilt head, camera and ancillary equipment weighing up to 55 kg (120 lb).

The Pro-Ped Pedestal is intended for use by television camera operators.



WARNING! If you do not understand how to operate this pedestal, do not attempt to use it.
Maintenance beyond that detailed in this Operators Guide must be performed only by competent personnel in accordance with the procedures laid down in the Maintenance Manual.

Further information

For further information or advice regarding this pedestal, please contact Vinten Broadcast Limited, your local Vinten distributor or visit our website.

For full details on maintenance and spare parts, please refer to the Pro-Ped pedestal Maintenance Manual and Illustrated Parts List - Publication Part No. 3983-9, obtainable from Vinten Broadcast Limited or your local Vinten distributor. For information on-line, visit our website at

www.vinten.com

Contents

	Page
Safety - read this first	3
Critical data	3
Technical data	4
Usage	4
Further information	4
Introduction	8
Operation	
Assembling the pedestal	9
Pressurizing the pedestal	10
Fitting and balancing the load	12
Using the Pro-Ped pedestal	
Height adjustment	13
Brakes	13
Cable guards	13
Pedestal movement	13
Transportation and storage	15
Servicing	
General	16
Cleaning	16
Routine checks	16
Adjustments	
Skid clamp adjustment	18
Elimination of radial and side play on the top stage	20
Parts list	21

Associated Publications
Pro-Ped Pedestal
Maintenance Manual
Part No. 3983-9

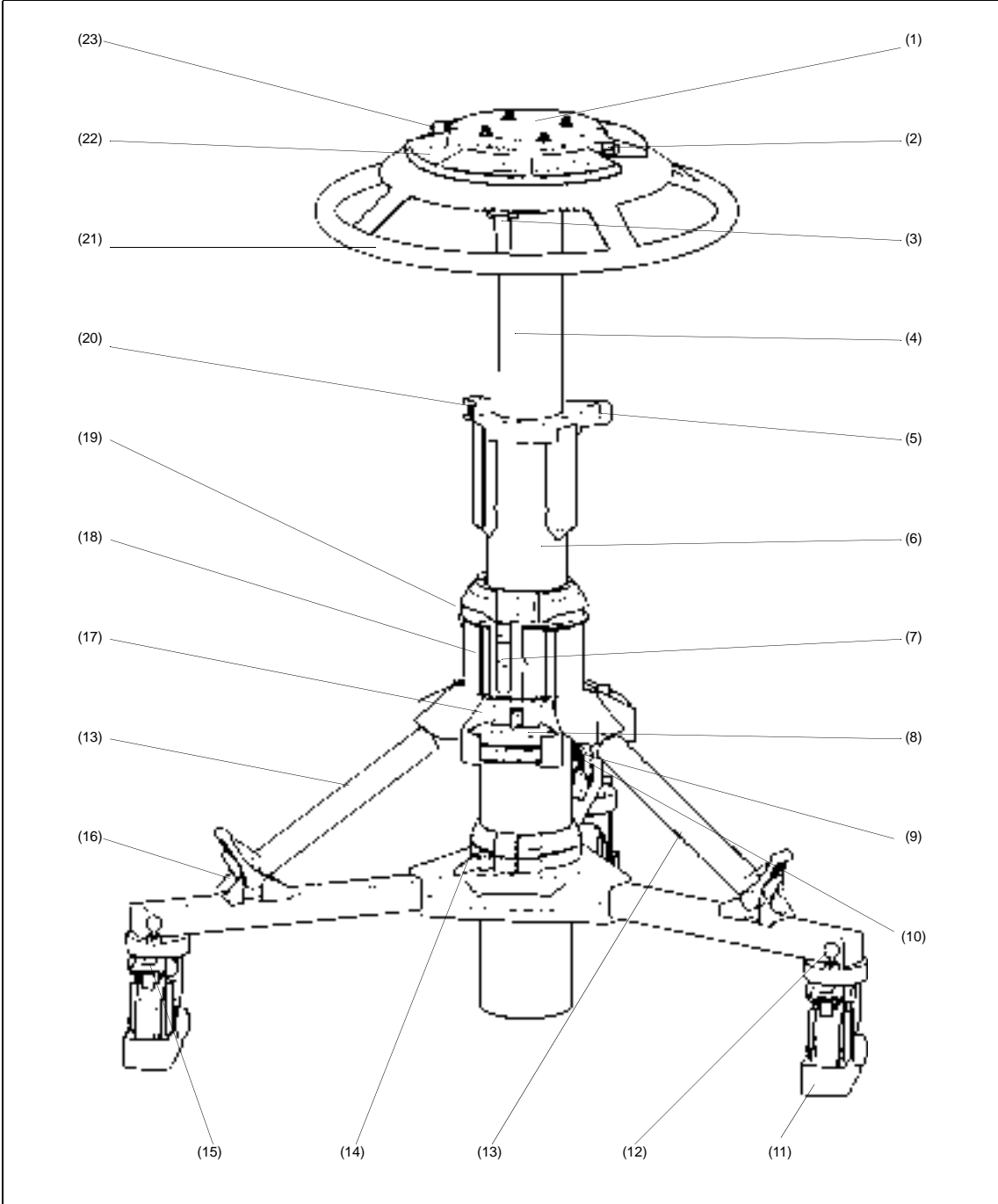

Pro-Ped Pedestal (Studio Version)

Pro-Ped Pedestal (Studio Version)

(1)	Four-bolt mounting plate
(2)	Control valve
(3)	Pressure gauge
(4)	Top stage
(5)	Drag control
(6)	Bottom stage
(7)	Safety catch
(8)	Trim weight
(9)	Long strut
(10)	Velcro strap
(11)	Cable guard
(12)	Track lock pin
(13)	Short strut
(14)	Skid clamp
(15)	Wheel brake
(16)	Foot support and strap
(17)	Trim weight stowage
(18)	Outer tube
(19)	Bottom clamp
(20)	Top clamp
(21)	Steering ring
(22)	Weight tray
(23)	Schrader valve and cap

Introduction

The Pro-Ped pedestal comprises a central two-stage telescopic column and a skid assembly with castoring wheels. For transport and storage, the column and skid may be separated and the skid folded.

The top stage (4) may be pressurized manually, using the self-contained pump, or from an external pressure source. Balance is achieved with approximately 1.5 bar pressure for every 10 kg of load (10 psi for every 10 lb). Trim weights (8) are provided for fine balance.

The skid comprises a centre casting with carrying handle, a fixed leg and two folding legs. Each leg carries a braked castoring wheel (15) and a foot support with strap (16) to secure the column leg. Two versions of the skid are available. The OB skid has 150 mm (6 in.) wheels. The studio skid has 125 mm (5 in.) wheels with cable guards (11) and track locks (12) which provide castor, track or steer movement of the pedestal.

Operation

Assembling the pedestal

Turn the skid upside-down, depress the leg locking plungers and swing each folding leg out until the plungers lock the legs in the open position.

Set the skid on the ground on its wheels and apply the brakes (15).

Install the column on the skid as follows:

Ensure that the rubber straps on each foot support (16) are to the outside of the ball joint.

Hold the column upright and release the Velcro retaining strap (10) holding the three struts. Raise the longer strut (9) to about 30° from the horizontal. The strut joint is adjusted to retain the strut in this position.

Lift the column, holding the two shorter struts (13) out from the column. Align the long strut with the fixed leg of the skid and carefully lower the column base into the skid centre, at the same time engaging the struts with the ball joints on each foot support.

Secure the struts to the supports with the rubber straps (16).

Tighten the skid clamp (14), using moderate hand pressure only. The clamp lever has a spring loaded ratchet-type action and is operated as follows:

Turn the clamp lever clockwise as far as possible.

Pull the lever outward against the spring pressure, return it to vertical and release.

Turn lever clockwise again.

Repeat until the skid clamp is sufficiently tightened.

Secure the Velcro retaining strap (10) clear of the skid wheels.

If the pedestal is already pressurized, the load may now be fitted. Otherwise pressurize the pedestal before fitting the load.

Pressurizing the pedestal



WARNING! This pedestal must be pressurized only with clean, dry air or nitrogen. A pressure reducing valve must be fitted to the pressure line between the gas cylinder and the outlet connection of the hose. The reducing valve must be screwed into the gas cylinder outlet. The maximum pressure on the outlet side of the reducing valve must not exceed 9.65 bar (140 psi). Do not pressurize the pedestal beyond the maximum safe working pressure indicated by the leading edge of the red sector on the gauge. The pedestal is fitted with a pressure relief valve as a safeguard against over-pressurization.
Do not attempt to adjust the pressure relief valve

The Pro-Ped may be pressurized manually, by using the self-contained pump, or from an external source.

A correctly pressurized pedestal will balance its payload such that it can be moved to any position over the full on-shot stroke of the top stage, with minimum effort, and it will maintain its position when the steering ring is released. Balance is achieved with approximately 1.5 bar pressure for every 10 kg of load (10 psi for every 10 lb).



WARNING! A pressurized pedestal will rise rapidly when safety catch is released. Do not lean over the pedestal when releasing the safety catch. Always restrain the pedestal by hand pressure on the steering ring when the safety catch is released.

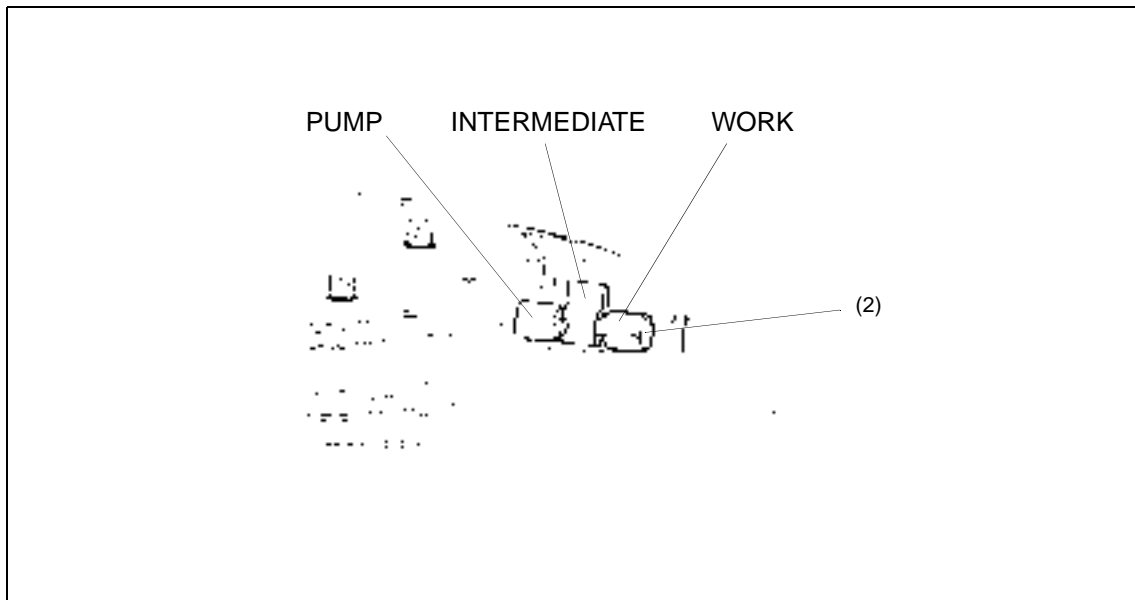

Control Valve

Pressurizing manually

To pressurize the pedestal manually, proceed as follows:

Set the control valve (2) to the PUMP position.



WARNING! Bottom stage elevation is assisted by a gas strut. The bottom stage will rise rapidly if released with no payload fitted. Do not lean over the pedestal when releasing the safety catch and/or the bottom clamp

Ensure that the bottom stage (6) is fully lowered and the red bottom clamp (19) is applied. Push down on the steering ring (21) against any residual pressure and release the safety catch (7).

Move the slide to the OFF position (O).

Using the steering ring (21), raise the top stage until fully extended. Commence pumping by lowering and raising the top stage over the upper half of its travel. When the pressure gauge (3) begins to register, pump the top stage over its full stroke. Stop pumping when maximum working pressure is reached (indicated by the lower edge of the red sector on the gauge) during the pumping stroke.



WARNING! A pressurized pedestal will rise rapidly if the control valve is set to WORK. Do not move the control valve directly from PUMP to WORK

Set the control valve (2) to the INTERMEDIATE position and allow the top stage to rise fully.

Set the control valve (2) to the WORK position.

Install the camera mount and payload and balance the load as described below.

Pressurizing from an external source

To pressurize the pedestal using an external source, proceed as follows:

Set the control valve (2) to the WORK position.



WARNING! A pressurized pedestal will rise rapidly when safety catch is released. Do not release safety catch when pedestal is pressurized and balancing load is not installed. Always restrain the pedestal by hand pressure on the steering ring when the safety catch is released

Push down on the steering ring (21) against any residual pressure and release the safety catch (7).

Move the slide to the OFF position (O).

Remove the Schrader valve cap (23) and connect the charging line from the pressure source.

Turn on the pressure supply and slowly increase the pedestal pressure. If not already fully extended, the top stage (4) will rise. Shut off the supply when maximum working pressure is reached, indicated by the lower edge of the red sector on the gauge (3).

Disconnect the charging line, but do not refit the Schrader valve cap at this stage.

Install the camera mount and payload and balance the load as described below.

.Fitting and balancing the load

After pressurization of the pedestal, the camera mounting and payload can be fitted and balanced. The Pro-Ped pedestal has the standard four-bolt mounting plate (1) which permits the use of various Vinten camera mounts including pan and tilt heads, Quickfix and Mitchell adapters. The mounting bolts are captive in the pedestal and the bolt heads are accessible from the underside of the mounting plate. When the camera mount has been fitted, the bolts should be tightened securely using a spanner of the correct size. A Vinten spanner, Part No. J551-001, is available for this purpose.

When the camera mount has been secured proceed as follows:

Fit the payload to the fully-extended top stage of the pedestal, ensuring that all items such as pan bars, prompters, lenses etc. are fitted. Attaching these items at a later stage may upset the pedestal balance. Install three trim weights (8) on the weight tray (22).

Using the Schrader valve cap (23), carefully reduce the pressure in steps of 0.15- 0.20bar (2-3psi) until the payload is correctly balanced. A correctly pressurized pedestal will balance its payload such that it may be moved to any position over the full on-shot stroke with minimum effort and will maintain its position when the steering ring is released.



**WARNING! The Schrader valve cap (23) forms a primary pressure seal.
Always replace the cap and screw it down finger-tight.**

Fine balance and temperature correction may be achieved by adding or removing trim weights (8).

Using the Pro-Ped pedestal

Height adjustment

Lower stage

NOTE: Lower stage pressure-assistance is provided by a gas strut located within the column. The strut is available in four pressure settings and the correct one should be installed according to the pedestal load. (See [Replacing gas struts](#))

The lower stage of the pedestal has an adjustment range of 395 mm (15.5 in.) and is pressure-assisted to aid elevation whilst the pedestal is loaded. To adjust the height setting:

Lower the top stage (4) and engage the top clamp (20).

Support the weight of the load by holding the steering ring and then slacken the bottom clamp (19) by turning the red knob counter-clockwise until the lower stage is free to move.

Use the steering ring to set the column at the required height and re-tighten the bottom clamp.

Top stage

The top stage of the column has an on-shot stroke of 410 mm (16.1 in.) and the load can be moved over this distance, in perfect balance, by raising and lowering the steering ring. The movement is adjustable for drag and this is set according to operator preference by means of the drag control (5) located at the top of the lower stage. Turn the control clockwise to increase the drag setting, and counter-clockwise to decrease it.

A clamp for the top stage (20) is fitted to the pedestal. This can be used to hold the top stage in position if fixed height operation is required. Move the clamp lever fully to the left to apply the clamp. Move it fully to the right to release the clamp.

Brakes

Each of the skid wheels is fitted with a foot operated brake (15). The brake is applied by pressing down on the lever situated above the wheel and released by pressing down on the centre 'pop-up' lever (15.1) which is raised when the brake is on.

Cable guards

The cable guards (11) fitted to the studio version are height-adjustable and should be set as required. Adjustment is carried out by slackening the knobs (11.1), setting the cable guards at the required height and re-tightening the knobs.

Pedestal movement

The wheels on the studio version of the skid can be locked in the straight-ahead position or set to castor freely. The castor/lock changeover is effected by spring-loaded track lock pins (12) on each wheel assembly. The pins on the folding legs have black knobs and the pin on the fixed leg has a red knob. To engage or disengage a pin, pull it up against the spring and turn through 90°. The

pin will only engage with the wheel when the wheel is properly aligned. This arrangement provides castor, track and steer motion.



WARNING! To ensure maximum stability, particularly when moving over uneven ground, reduce pedestal height to a minimum.

Castor motion

For castor motion, disengage all three track locks (12). The skid can now be moved freely in any direction.

Tracking motion

For tracking motion, engage all three track locks (12). The skid can now track backwards and forwards in a straight line.

Steer motion

For steer motion:

Position the skid so that the fixed leg (with the red knob) is in the direction of travel. Disengage the red track lock (12).

Engage the black track locks (12).

With the fixed leg of the skid facing forwards the skid can now be moved with a 'steering-type' motion.

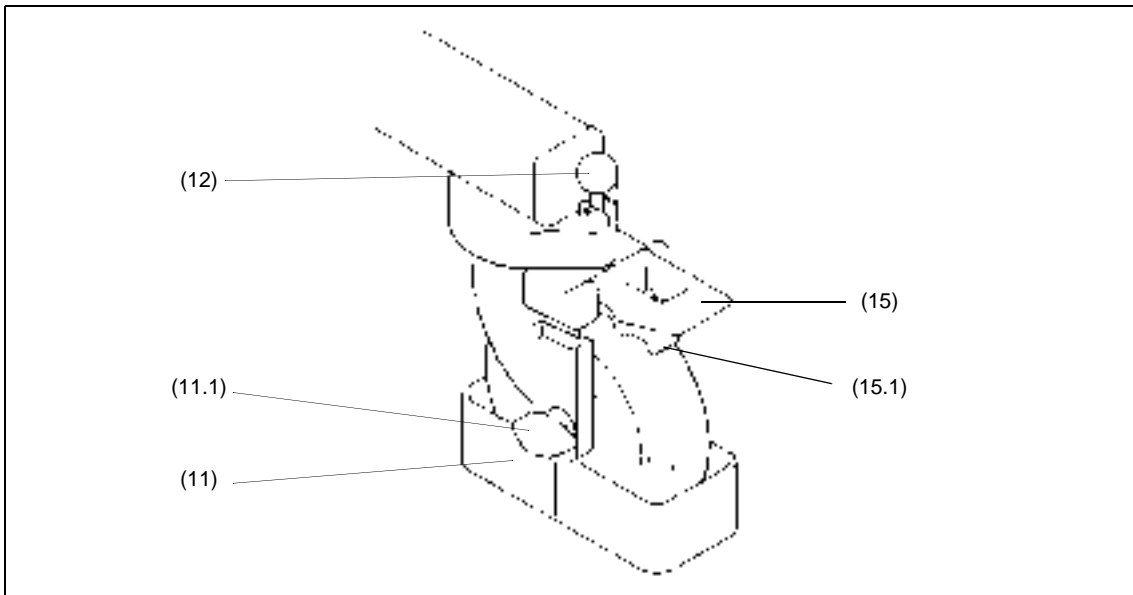

Brakes, Cable Guards and Pedestal Movement

Transportation and storage



WARNING! Local, national or international regulations may apply to the transport and storage of pressurized pedestals.

NOTE: It is not necessary to reduce the pedestal pressure prior to transportation or storage and the pan and tilt head may be removed with the pedestal in the fully depressed and locked position. However, to facilitate removal of the camera and mounting, pressure should be reduced to 3.5 bar (50 psi).

The pedestal may be dismantled for transportation and storage. Proceed as follows:

Apply the brakes (15).

Set the control valve (6) to the WORK position.

Lower the top stage (4), then set the control valve to PUMP



WARNING! Ensure that the payload is removed and trim weights are secured in the trim weight stowage before dismantling the pedestal.

Remove the load and secure any trim (8) weights in the trim weight stowage (17).

Set the safety catch slide (7) to ON (I) and fully depress both columns until the safety catch engages.

Release the skid clamp (14).

Release the three rubber foot straps (16) from the struts.

Raise the longer strut (9) (on the fixed skid leg), which will remain raised when released. Raise and hold the two shorter struts (13), then lift the complete column vertically off the skid.

Secure the struts with the Velcro strap (10).



WARNING! The column will be unstable if stood on its base.

Depress the locking plungers and fold the skid legs, ensuring that the plungers lock in the closed position.

Servicing

General

The Pro-Ped pedestal is robustly made to high engineering standards and little attention is required to maintain serviceability save regular cleaning. Attention to the following points will ensure a long and useful service life with minimum need for repair.

Cleaning

During normal studio use, the only cleaning required should be a regular wipe over with a lint-free cloth. Dirt accumulated during storage or periods of disuse may be removed with a semi-stiff brush. Particular attention should be paid to the flats on the top stage of the column.

NOTE: Do NOT use oil or grease on any exposed part of the column. This is unnecessary and traps dirt which acts as an abrasive.

Use out-of-doors will require special attention, especially in adverse conditions. Salt spray must be washed off with fresh water at the earliest opportunity. Do not allow water to enter the column. Sand and dirt acts as an abrasive and should be removed with a semi-stiff brush or vacuum cleaner.

NOTE: Use only detergent-based cleaners. Do NOT use solvent- or oil-based cleaners, abrasives or wire brushes to remove accumulations of dirt, as these damage the protective surfaces.

Routine checks

Check the following during normal use:

- Check for ageing and cracking of the rubber strut securing straps and renew if necessary.

- Check the effectiveness of the clamps.

- Check for radial or side play in the in the top stage.

Adjustments

Adjustments that may become necessary after considerable use are as follows:

- Taking up wear in the bottom clamp.

- Taking up wear In the skid clamp.

- Elimination of radial and side play in the top stage.

Bottom clamp adjustment

When applied finger-tight, the 'V' notch on the bottom clamp knob should be within the limits shown. To adjust the bottom clamp (19):

Tighten the clamp finger-tight.

Remove the hole plug (19.1). Remove the screw (19.2) and washer (19.3) securing knob (19) to the spindle (19.4).

Remove the knob, turn counter-clockwise, then replace on spindle (19.4) so that the 'V' notch on the clamp knob is within the limits shown.

Degrease screw (19.2), coat with Loctite 222E and secure knob with washer (19.3) and screw (19.2). Replace hole plug (19.1).

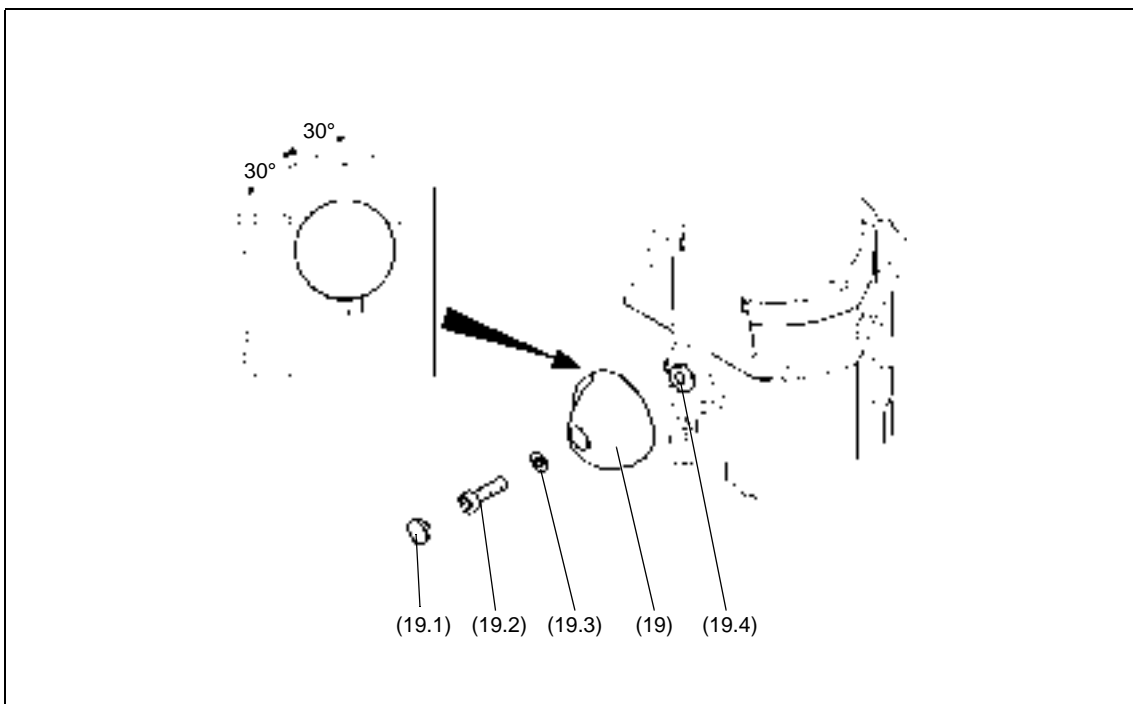

Bottom Clamp Adjustment

Skid clamp adjustment

To adjust the skid clamp:

The skid clamp (14) is applied or released by turning the handle clockwise or counter-clockwise. The handle has a pull-off/push-on ratchet adjustment. To take up wear, pull the handle away from the spindle, rotate counter-clockwise and release.

Repeat the above procedure, as necessary, until the clamp locks when applied but allows free movement when released.

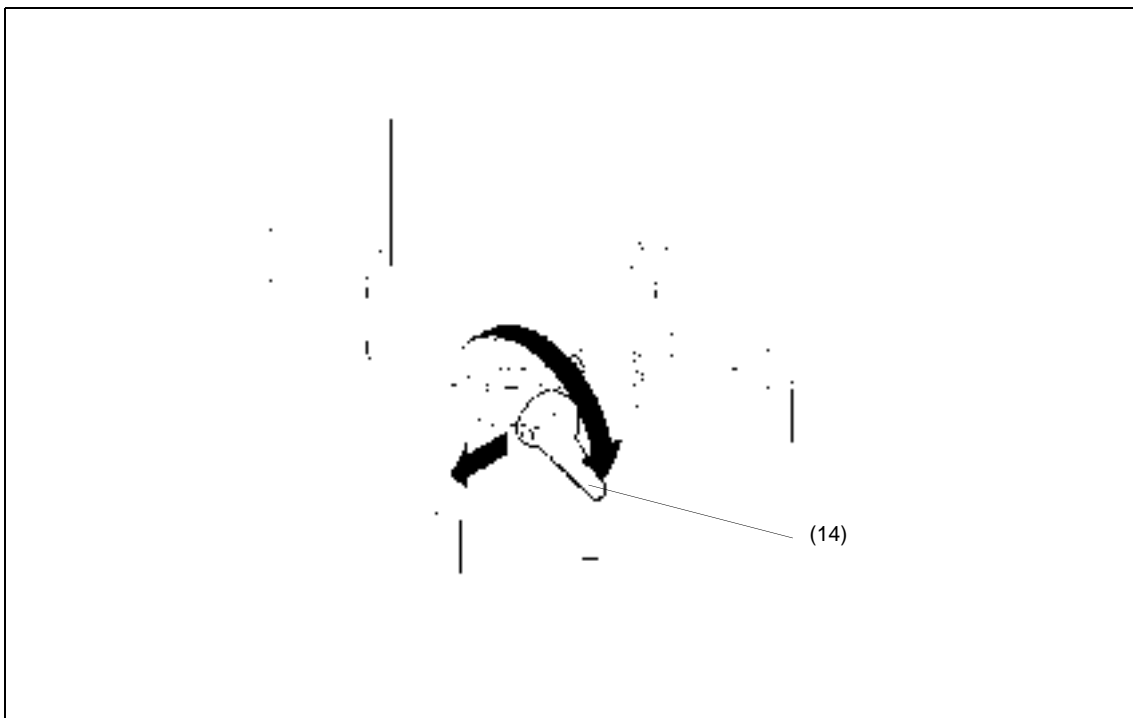

Skid Clamp Adjustment

Replacing gas struts

Bottom stage elevation assistance is provided by a gas strut located in the telescopic column. To allow for various column loads, four versions of the strut are available, each designed to operate over a particular load range.

To replace the bottom stage gas strut:

Apply the wheel brakes (15), set the top stage (4) to its maximum height and engage the top clamp.



WARNING! Set the bottom stage to its maximum height. If this is not done the gas strut will be under compression. Attempted removal of a compressed gas strut may lead to serious injury.

Remove the load, release the bottom clamp (19) and set the bottom stage (6) to its maximum height.

Tip the pedestal over and carefully lay it on its side.

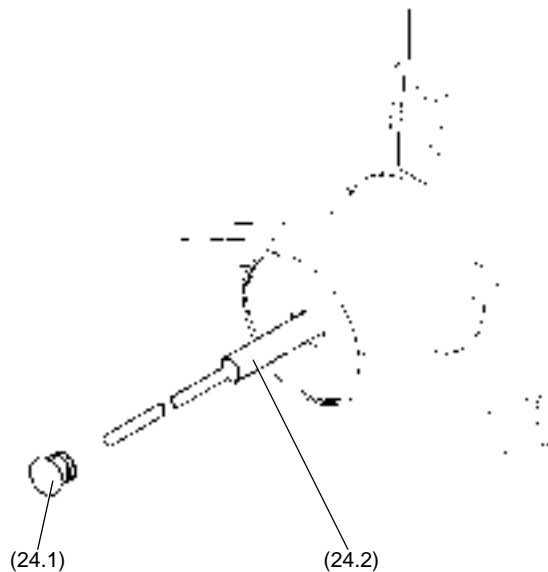

PAYLOAD	FORCE	PART No.
0-18 kg (0-40 lb)	270 N	3328-307
18-32 kg (40-70 lb)	360 N	3328-306
32-55 kg (70-120 lb)	450 N	3328-305

Replacing gas struts

Unscrew and remove the centre end plug (24.1) from the base of the telescopic column.

Withdraw the gas strut (24.2) from the column.

Fit the new gas strut, cylinder end first, carefully guiding it up through the column until it is fully engaged. The strut is correctly fitted when the thread on the end plug (24.1) can be started in the column without compressing the strut.

Tighten the end plug (24.1).

Carefully stand the pedestal upright.

Elimination of radial and side play on the top stage.

If excessive radial or side play is apparent in the moving column, refer to the appropriate section in the Maintenance Manual. This adjustment should be carried out by a competent person.

Parts list

The following lists include main assemblies, user-replaceable spare parts and optional accessories. For further information regarding repair or spare parts, please contact Vinten Broadcast Ltd or your local distributor.

For information on-line, visit our website at

www.vinten.com.

Item	Part No.
Pro-Ped, OB version	3983-3B
Pro-Ped, studio version,	3983-3C
Column	3983-11
OB skid	3985-3B
Studio skid	3985-3C
Gas strut - 0-18 kg (0-40 lb)	3328-307
Gas strut - 18-32 kg (40-70 lb)	3328-306
Gas strut - 32-55 kg (70-120 lb)	3328-305
Trim weight	3328-328
Spanner - for head bolts	J551-001